

Wedge Clamps for Flat Clamping Edge

electro-mechanical, max. operating force 240 kN
 self-locking, with position monitoring

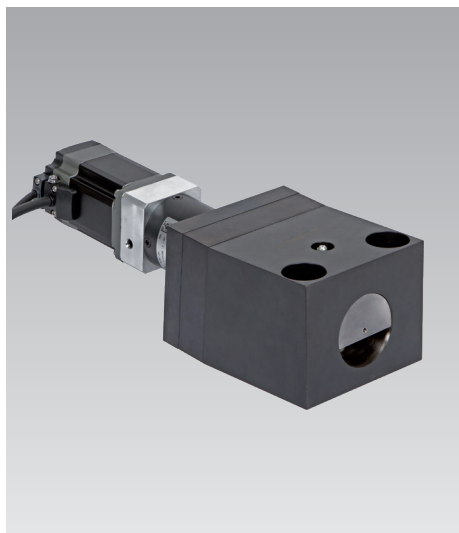

Advantages

- Increased operating safety by mechanical self-locking and monitoring of the clamping position
- Control of the following functions: clamping and unclamping position, clamping force and speed of the clamping bolt
- Compact electro-mechanical force package
- Reclamping on the clamping point of yielding clamping edges possible
- Even in case of power failure, safe and self-locking clamped
- Optimum automation element
- High-quality corrosion protection for drive and housing

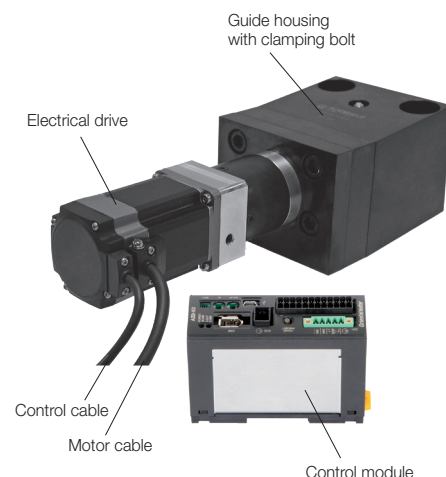

Application

Electro-mechanical wedge clamps are used for hydraulic free clamping of dies on sliding tables, in injection moulding machines and presses on bed and ram.

Application examples

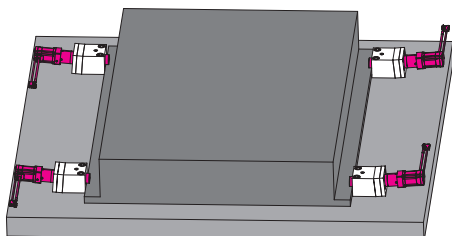

Sliding tables

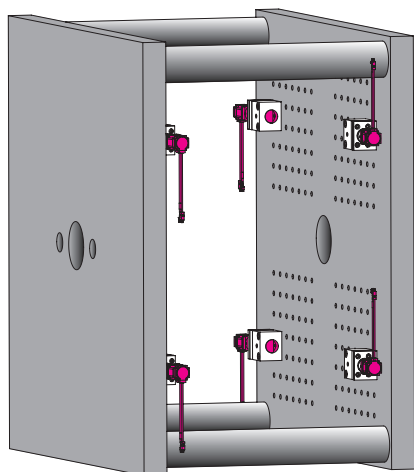

Injection moulding machines

Description

The clamping bolt of the wedge clamps is operated by a 24 VDC direct current drive via a snail transmission and a spindle stroke transmission.

The self-locking spindle lifting gear stops the drive in case of power failure and maintains it safely in the reached position.

During clamping, the clamping bolt is moved with low inclination onto the flat clamping edge. The clamping bolt is completely retracted in the guide housing in off-position.

The wedge clamp is equipped with an integrated position monitoring. In addition, fault messages can be output.

The wedge clamp is controlled via a control module equipped with different data interfaces.

Version with angular gear

By default, the electrical drive is mounted at the rear of the guide housing.

Alternatively, a version with angular gear is available. (see page 2)

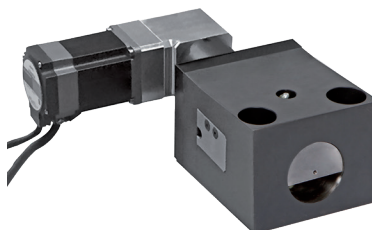

Delivery

● Wedge clamp with drive

Electrical connection:

- motor cable, firmly connected (L = 280mm)
- control cable, firmly connected (L = 280mm) (extension cable: see page 3)

● Control module

Position monitoring

The position monitoring is integrated in the drive. The following positions are reported on the control module:

- Clamping bolts in off-position (retracted)
- Clamping bolts in clamping position (extended)

Possible fault messages

- Outside the clamping range
- Cable break
- Current peaks
- Over temperature
- Clamping force is not reached

Technical data

Dimensions

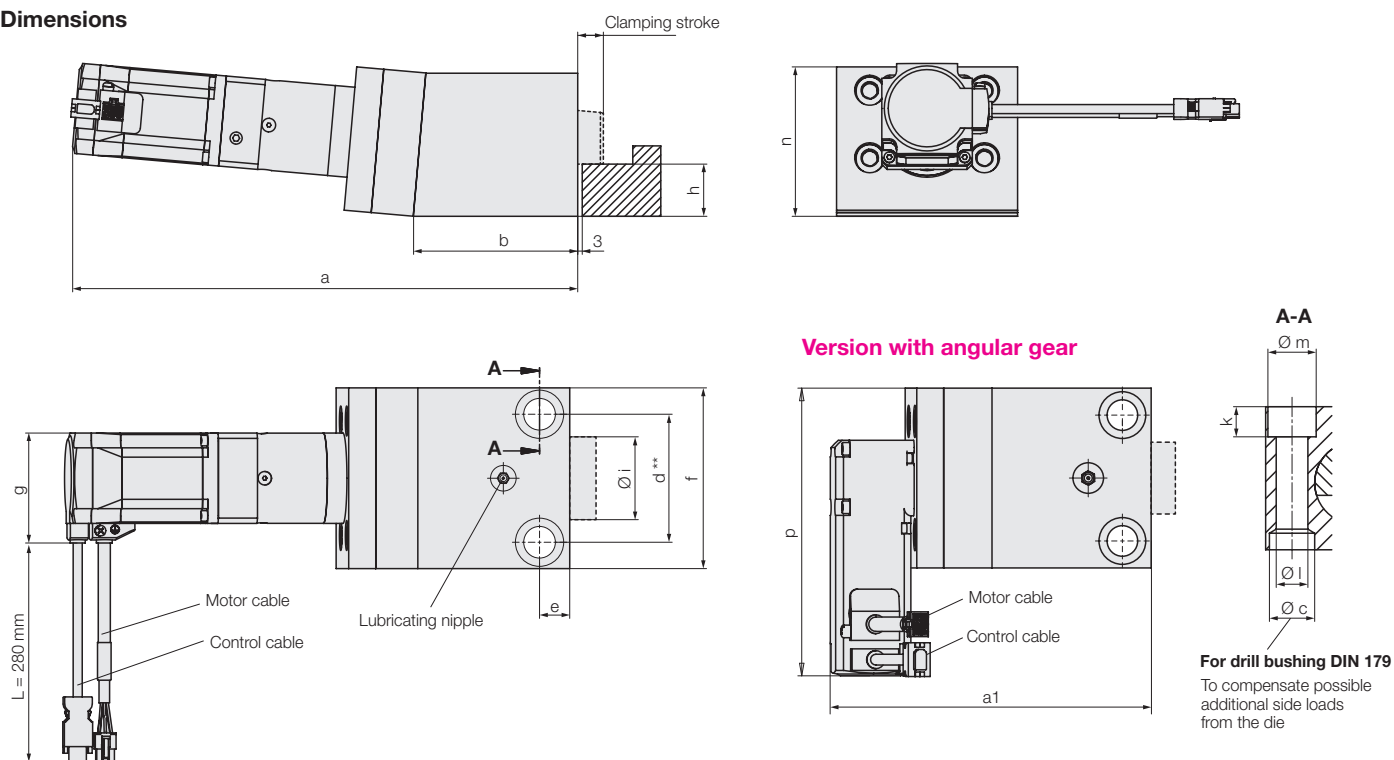

Technical data

Adm. operating force for screws 8.8 (DIN 912)	[kN]	35	60	130	190
Adm. operating force for screws 10.9 (DIN 912)	[kN]	50	90	160	240
Fastening screw		M 12	M 16	M 20	M 24
Total stroke	[mm]	20	25	25	28
Clamping stroke	[mm]	12	16	17	20
Max. temperature	[°C]	70	70	70	70
Clamping force max.	[kN]	15	25	35	35
a	[mm]	199	286	335	350
a1	[mm]	–	178	276	292
b	[mm]	60	95	109	125
Ø c H7 x depth	[mm]	18/7	26/9	30/11	35/11
d** (when using drill bushings ± 0.02)	[mm]	48	70	85	105
e	[mm]	14	16	20	25
f	[mm]	70	100	120	150
g	[mm]	55	55	73	73
h (±0.1)	[mm]	22	25	35	40
Ø i	[mm]	30	40	55	70
k	[mm]	13	17	20	26
Ø l	[mm]	13	17	21	26
Ø m	[mm]	20	26	32	40
n	[mm]	60	78	100	110
p	[mm]	–	160	220	235
Weight	[kg]	3,3	10	15	22
Rated voltage	[V DC]	24	24	24	24
Current for empty running	[A]	1,5	1,5	1,5	1,5
Max. current	[A]	3,8	3,8	3,8	3,8
Code class		IP 54	IP 54	IP 54	IP 54
Lifting speed	[mm/s]	2	2	2	2
Part-no. without angular gear		826730101	826740101	826750101	826760101
Part no. with angular gear		not available	826740201	826750201	826760201

** on request also available with Euromap grid

Accessories

Drill bushings DIN 179	12 x 12	17 x 16	21 x 20	26 x 20
Part no.	3300285	3300287	3300288	3300289

Wedge clamping element

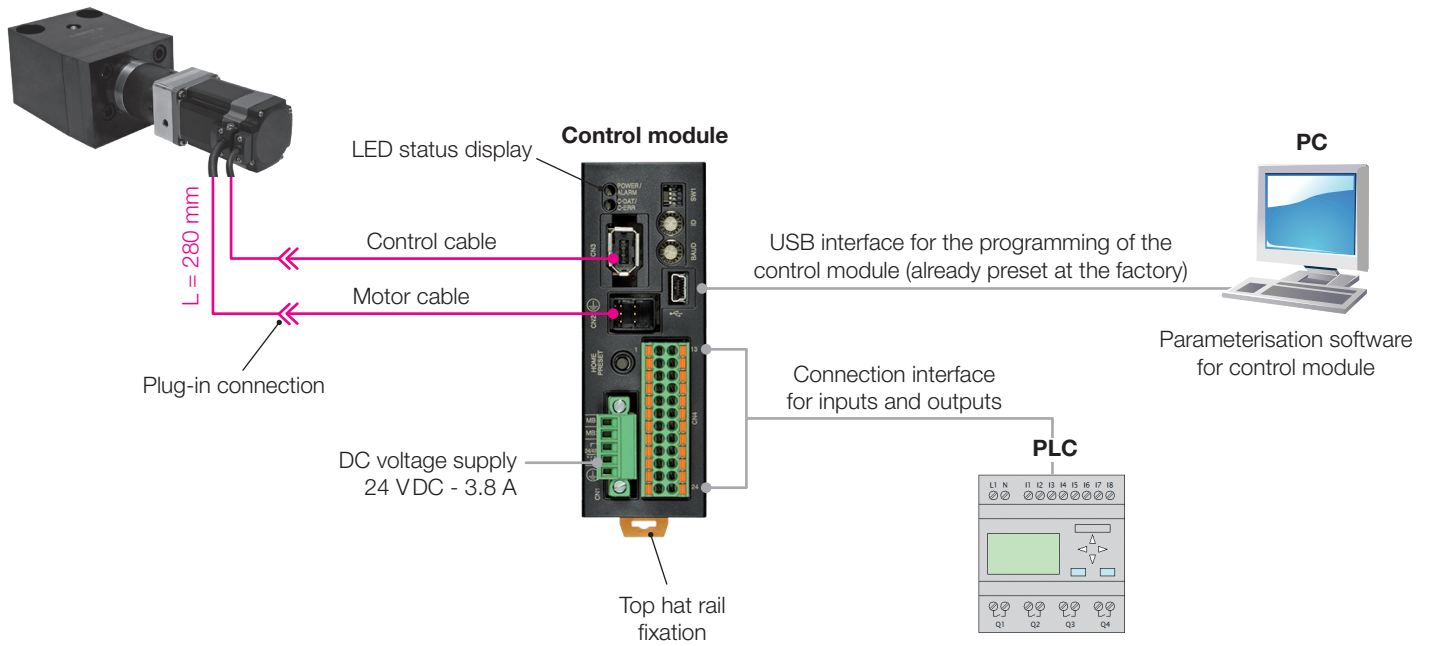

Accessories

Extension cable

Control cable and motor cable as set



Length of cable	5 m	10 m	15 m	20 m
Part no.	209750046	209750047	209750048	209750049

Options

on request

- Electromagnetic brake in the clamping element
- Drive laterally angled with angular gear
- Network-converter for CC-Link 1.1, mechatronics II and III and EtherCAT
- Ethernet/network connector RJ45 as the connection between the control modules
- Control module with 48 V DC voltage supply

