

Extending clamp double-acting, with mechanical lock



ROEMHELD
HILMA ■ STARK



Applications:

- preferably on press beds
- for clamping and locking dies and moving bolsters in presses

Clamping:

For clamping, the cylinder piston pushes the clamping lever into the clamping position. Released by the hydraulic sequence control, pressure is then applied to the clamping and locking mechanism.

Once the clamping force is built up, the clamping element is self-locking. This *mechanical lock* prevents unintentional unclamping of the die even if there is a loss of pressure.

Unclamping:

For unclamping, the clamping and locking mechanism is hydraulically unlocked.

Released by the hydraulic sequence control, pressure is applied to the cylinder piston which pushes the clamping lever into the unclamping position.

Unclamping and clamping positions are monitored by inductive proximity switches.

Special features:

- ◆ compact housing and high power density
- ◆ high functional reliability ensured by position monitoring and automatic cycle
- ◆ self-locking by mechanical lock
- ◆ low operating pressure of 100 bar
- ◆ easy installation

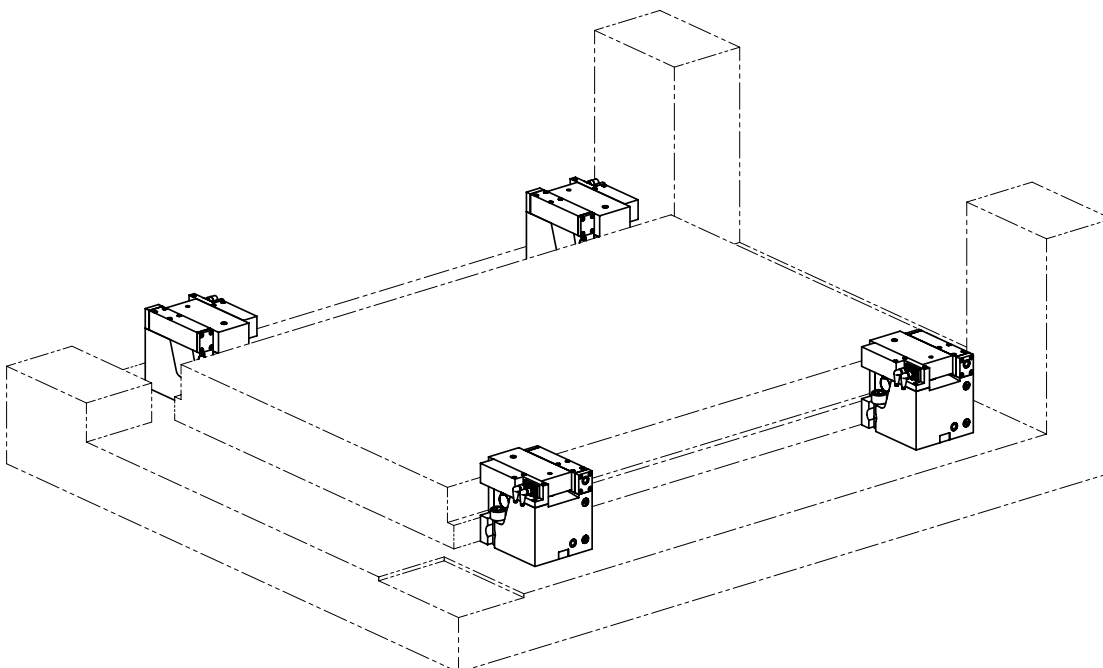



Extending clamp double-acting, with mechanical lock

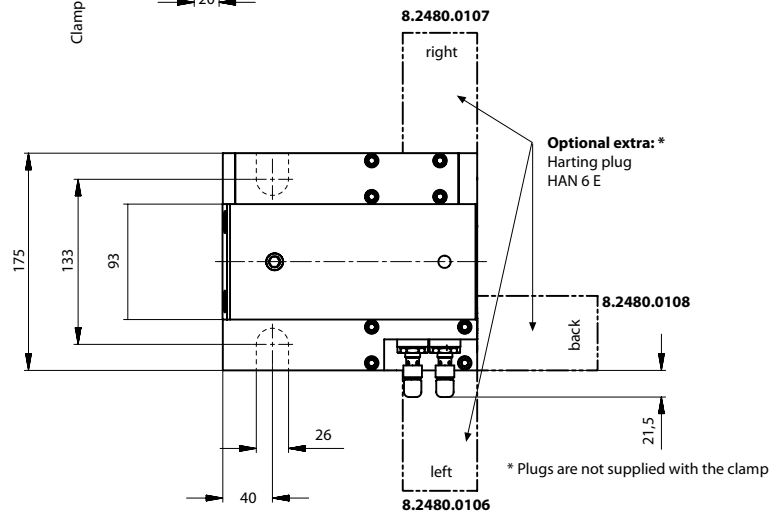
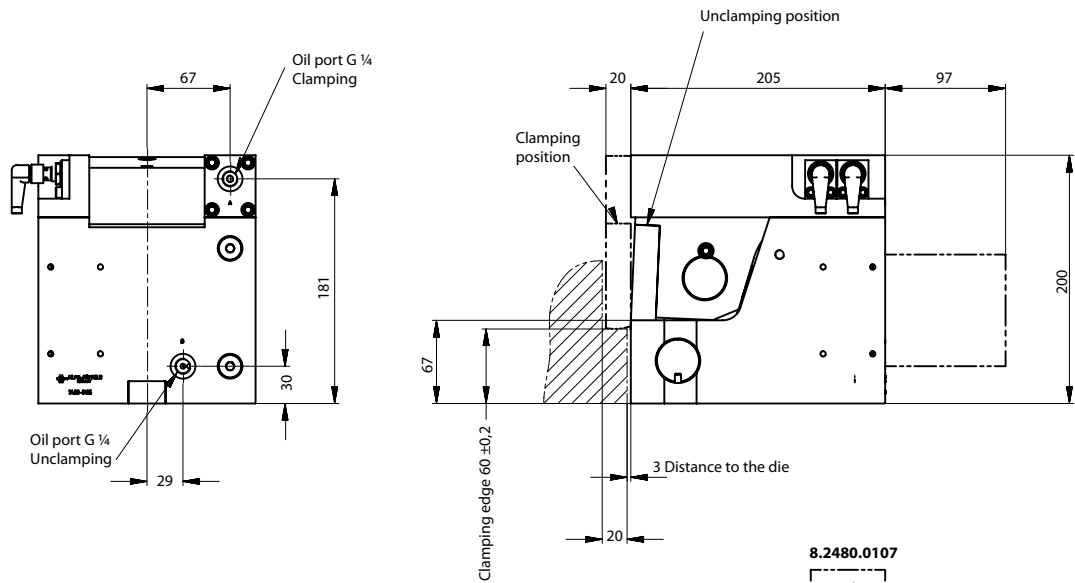

Clamping force at 100 bar (kN)	200
Perm. retaining power (kN)	250
Working pressure (bar)	100
Oil consumption clamping (cm ³)	204
Oil consumption unclamp.(cm ³)	188
Pump delivery (l/min)	1,6 – 2,5
Operating temperature (°C)	70
Screws DIN 912-8.8	M 24
Required torque (Nm)	660
Weight (kg)	46
Part no.	8.2480.0105

Special designs are available at request.

- Design and position of plug-in connection for proximity switches
- Proximity switches for temperatures of up to 120°C
- Cover plate for protection in extremely dirty environments
- Clamping edge height larger than 60 mm

Hydraulic diagram

