

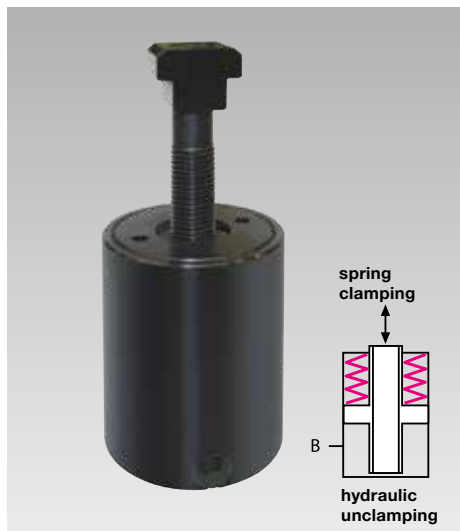

Hollow Piston Cylinders
spring clamping - hydraulic unclamping
single acting, clamping force 50 kN



Advantages

- Hydraulic supply is only required for unclamping, i.e. for a short time
- Ideal force transmission
- Convenient and compact design with gripping surface
- No interfering edges when inserting the dies
- Easy to retrofit
- Easy installation

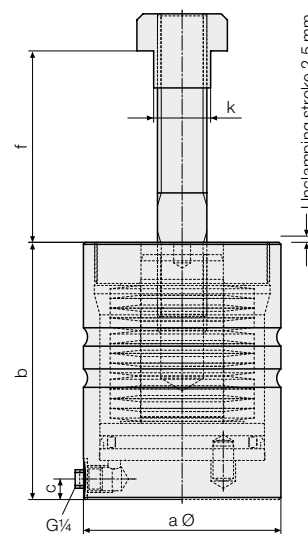

Application

These hollow piston cylinders are used for unpressurised long-term clamping of dies or fixtures on press beds and rams. Thanks to their compact design, they can also be used where the available space is limited.

Description

The element is manually placed on the clamping edge of the die. Unclamping by the application of hydraulic pressure to the piston and clamping by spring force. By means of the T-bolt the die is clamped against the clamping surface of the press ram or bed.

Hollow piston cylinder, complete

adjusted and secured with T-bolt
Please specify dimension "f" when ordering

Dimension "f" = die clamping edge + web height + unclamping stroke

	[mm]	22	28
For T-slot			
Clamping force	[kN]	50	50
Unclamping pressure	[bar]	175	175
Unclamping stroke	[mm]	2.5	2.5
Oil volume /1 mm stroke	[cm ³]	5	5
a	[mm]	96	96
b	[mm]	125	125
c	[mm]	10	10
k	[mm]	22	28
Weight	[kg]	6.8	7.0
Part no.		8 14032200	8 14032800

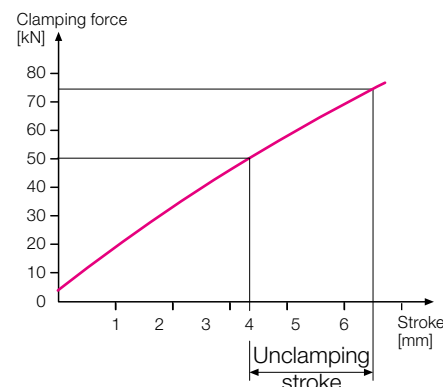

Accessory

Parking station during die change

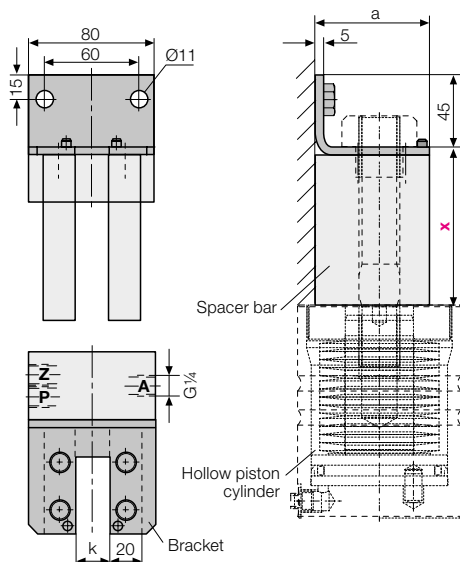

Spacing "x" = "f" - 4 mm

Bracket mounted with spacer bars
(without connector block)

	Part no.	8 27532230	8 27532830
T-slot width	k [mm]	22	28
	a [mm]	72	85

Separate bracket

Part no.	2753-220	2753-280
----------	----------	----------

Special designs on request

