



**Hollow Piston Cylinders**

single acting, hydraulic clamping and spring unclamping

max. clamping force of 30 kN up to 104 kN, max. operating pressure 400 bar



**Advantages**

- Optimum adaptation to the clamping surface by spherical disk
- T-bolt, secured against loosening
- Ideal force transmission
- Convenient and compact design with gripping surface
- Large clamping stroke
- No interfering edges when inserting the dies
- Easy to retrofit
- Piston hardened and ground
- Easy installation
- Fully resilient stroke limitation

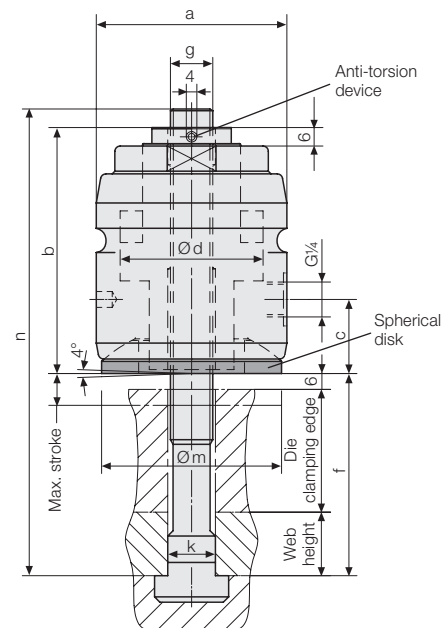

**dimension "f" = die clamping edge + web height + ½ stroke**

**Application**

These hollow-piston cylinders are used for clamping and locking on machines and plants, on press bed and ram.

Due to the manageable and compact design, hollow-piston cylinders are especially suitable where space is limited.

The use is possible at ambient temperatures up to a maximum of 120 °C.

**Description**

The element is manually placed on the clamping edge of the die.

Clamping by the application of hydraulic pressure to the piston and unclamping by spring force. By means of the T-bolt the die is clamped against the clamping surface of the press ram or bed.

**Hollow piston cylinder with T-bolt**

adjusted and secured (please specify dimension "f" when ordering)

For T-slot	[mm]	18	22	28	36
Clamping force at 400 bar	[kN]	60	60	104*	104*
Spring return force, min.	[N]	320	320	570	570
Piston Ø d	[mm]	54	54	70	70
Stroke	[mm]	12	12	12	12
Total oil volume	[cm³]	18	18	32	32
a	[mm]	72	72	90	90
b	[mm]	93	93	105	105
c	[mm]	28	28	24	24
g	[mm]	M 16	M 20	M 24	M 30
k	[mm]	18	22	28	36
m	[mm]	68	68	78	78
Weight	[kg]	2.39	2.67	4.77	5.29
<b>Part no.</b>		<b>821341802</b>	<b>821342202</b>	<b>821352802</b>	<b>821353602</b>

Max. operating pressure 400 bar, \* 160 kN on request

**Hollow piston cylinder without T-bolt**

Weight	[kg]	2.1	2.09	3.67	3.49
<b>Part no.</b>		<b>821340102</b>	<b>821341102</b>	<b>821350102</b>	<b>821351102</b>

**T-bolt, separate**

For T-slot	[mm]	18	22	28	36
n	[mm]	160	200	250	250
Property class		12.9	12.9	12.9	8.8
Weight	[kg]	0.29	0.58	1.10	1.8
<b>Part no.</b>		<b>5700022</b>	<b>5700023</b>	<b>5700024</b>	<b>5700048</b>

**Example of ordering**

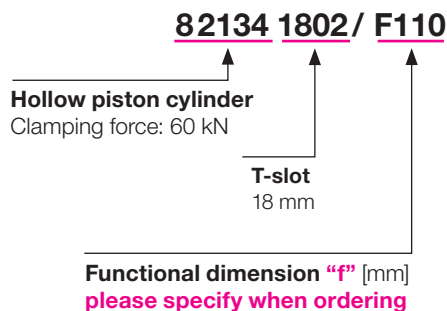

**Important note!**

If hollow piston cylinder and T-bolt are supplied separately, adjust them to suit dimension "f" and secure them.

Accessories

**Parking station without position monitoring**

accommodates the hollow piston cylinder during die change.

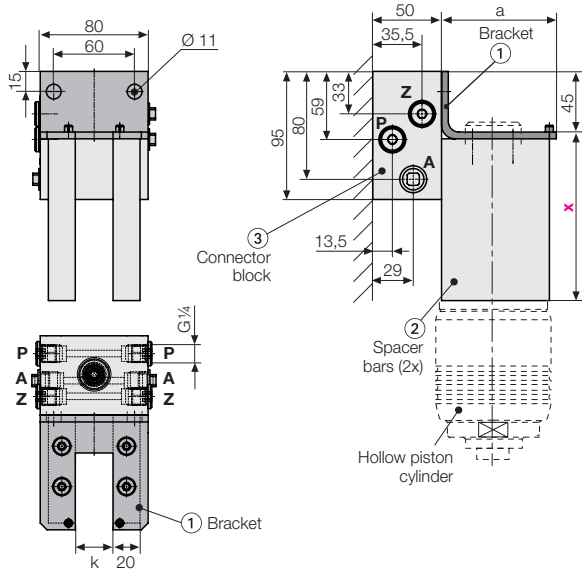

**Distance dimension "x"  
= Dimension "f" - 1/2 stroke  
please specify when ordering**

Hydraulic circuit diagram

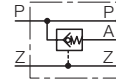

Application with integral check valve

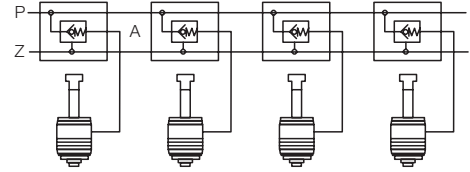

Part numbers

for hollow piston cylinder type

	2134	2134	2135	2135
T-slot width [mm]	18	22	28	36
<b>Bracket ①</b>	<b>Part no. 2753 180</b>	<b>2753 220</b>	<b>2753 280</b>	<b>2753 360</b>
<b>Bracket ① with mounted spacer bars ②</b>	<b>Part no. 82753 1830</b>	<b>82753 2230</b>	<b>82753 2830</b>	<b>82753 3630</b>
<b>Bracket ① with spacer bars ② and connector block ③</b>	<b>Part no. 82753 1850</b>	<b>82753 2250</b>	<b>82753 2850</b>	<b>82753 3650</b>
<b>Connector block ③ with integral check valve, separate</b>	<b>Part no. 82753 4002</b>	<b>82753 4002</b>	<b>82753 4002</b>	<b>82753 4002</b>

Special designs on request

**Parking station with position monitoring**

An inductive proximity switch indicates when a hollow piston cylinder is mounted to the parking station.

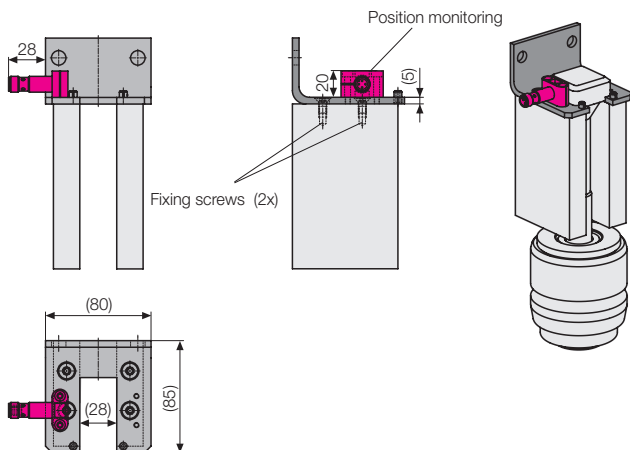

Position monitoring

Control options

- The correct number of clamping cylinders and thus sufficient clamping force is available
- Operator protection: no clamping cylinder will be forgotten
- Control of a selective selection per tool size is possible

Please contact us!

Other accessories

- **Hydraulic power units**  
see product group 7
- **Hydraulic accessories**  
see product group 11
- **Angular rotary coupling**  
Part no. 9208 176

# Hollow piston cylinder “L” design without spherical disk

## Hollow piston cylinder “L” design without spherical disk

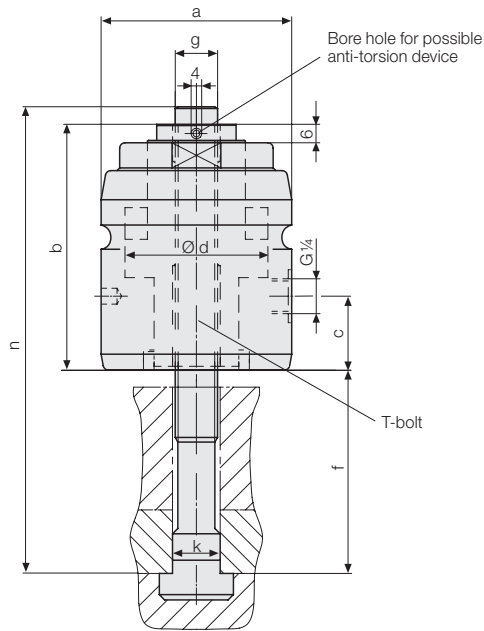

### Hollow piston cylinder “L” design without spherical disk **with T-bolt**

- with adjusted and secured T-bolt (specify dimension ‘f’ when ordering)
- without spherical disk

For T-slot	[mm]	14	16	18	22	22	28	36
Clamping force at 400 bar	[kN]	30	40	60	60	60	104	104
Spring return force, min.	[N]	255	360	320	400	320	570	570
Piston Ø d	[mm]	35	42	54	54	54	70	70
Stroke	[mm]	8	8	12	6	12	12	12
Total oil volume	[cm <sup>3</sup> ]	6	8	18	9	18	32	32
a	[mm]	50	58	72	72	72	90	90
b	[mm]	64.5	66.5	92.5	67	92.5	104	104
c	[mm]	13	14	28	12	28	24	24
g	[mm]	M12	M14	M16	M20	M20	M24	M30
k		14	16	18	22	22	28	36
m		G 1/8	G 1/8	G 1/4	G 1/4	G 1/4	G 1/4	G 1/4
Weight	[kg]	1.0	1.2	2.5	2.0	2.8	4.8	5.4
<b>Part no.</b>		<b>821321432</b>	<b>821331632</b>	<b>821341832</b>	<b>821342222</b>	<b>821342232</b>	<b>821352832</b>	<b>821353632</b>

Max. operating pressure 400 bar

### Hollow piston cylinder “L” design without spherical disk **without T-bolt**

- without spherical disk

For T-slot	[mm]	14	16	18	22	22	28	36
Weight	[kg]	0.75	1.0	2.2	1.7	2.2	3.8	3.6
<b>Part no.</b>		<b>821320132</b>	<b>821330132</b>	<b>821340132</b>	<b>821341122</b>	<b>821341132</b>	<b>821350132</b>	<b>821351132</b>

#### Important note!

If hollow piston cylinder and T-bolt are supplied separately, adjust them to suit dimension “f” and secure them.

#### Accessories

##### T-bolt, separate

For T-slot	[mm]	14	16	18	22	22	28	36
n	[mm]	125	125	160	200	200	250	250
Property class		12.9	8.8	12.9	12.9	12.9	12.9	8.8
Weight	[kg]	0.16	0.19	0.29	0.58	0.58	1.1	1.8
<b>Part no.</b>		<b>5700143</b>	<b>5700144</b>	<b>5700022</b>	<b>5700023</b>	<b>5700023</b>	<b>5700024</b>	<b>5700048</b>

## Variant with a total stroke of 20 mm

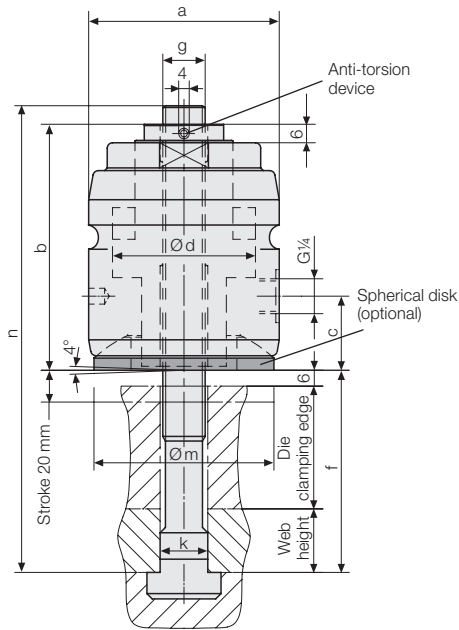

Optimum adaptation to varying heights of the clamping edges of dies by an increased total stroke of 20 mm (higher total stroke on request).

Technical design, clamping forces and dimensions correspond to the standard design. Due to the increased total stroke, dimension "b" is greater than indicated on page 1.

### Total stroke 20 mm:

Dimension "b" with a clamping force of 60 kN:  
120 mm

Dimension "b" with a clamping force of 104 kN:  
132 mm

## Variant with variable clamping dimension

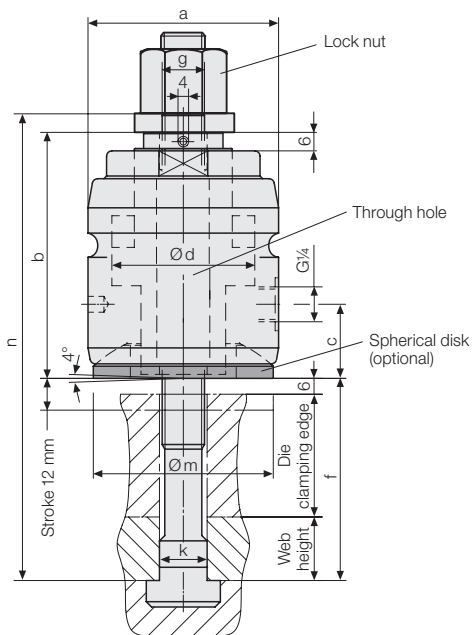

Freely adjustable and flexible adaptation to suit varying heights of clamping edges of the dies by quick and easy adjustment of the tie rod by means of a lock nut.

The tie rod is inserted through the hollow piston cylinder and adjusted to the correct dimension by means of the lock nut.

In this design, the cylinder has a through hole instead of a thread.

Technical design, clamping forces and dimensions correspond to the standard design.

### Important notes

Increased risk of injury in the case of an incorrect adjustment of the variants with higher total stroke or variable clamping dimension.

The clamping stroke must be less than 6 mm.