



Pull Clamps with T-Slot

clamping force from 55 to 144 kN

double acting, max. operating pressure 400 bar



Advantages

- Installation directly in the bed or in the ram
- Compact design
- Dies are easily adaptable
- Bed and ram can also be used for manual clamping
- Ideal force transmission with centrally arranged clamping elements
- Optimum use of bed and ram surfaces

Application

- Installation in press rams
- Installation in press beds
- Integrated in an intermediate plate
- When the available space is limited

Description

The pull clamp with T-slot facilitates a die standardisation by means of T-slot bars or T-nuts on the die.

The hydraulic oil supply is made either through drilled holes in the bed and the ram or through pipes.

Tie rod and piston are hardened and ground. The hydraulic system is protected against dirt by wiper rings.

Die clamping in a press

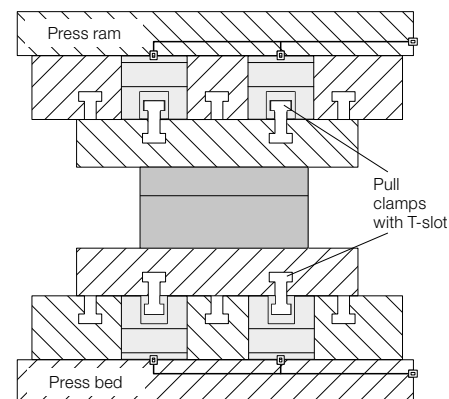

Ram: clamping of the upper die with double T-slot bars

Bed: clamping of the lower die with firmly mounted T-slot bars

Technical data Dimensions

Dimensions

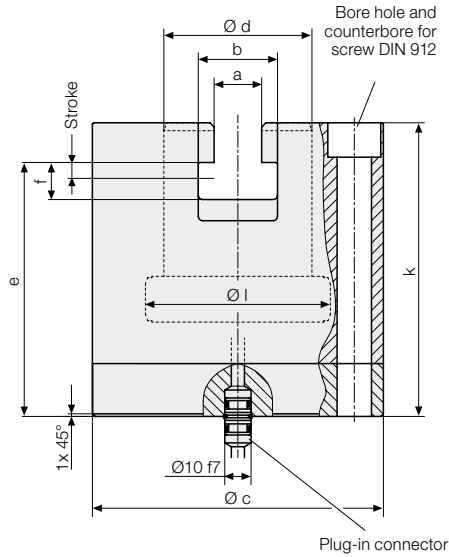

Location hole

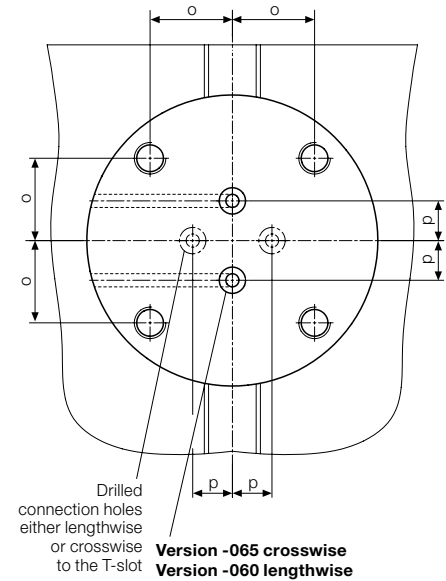
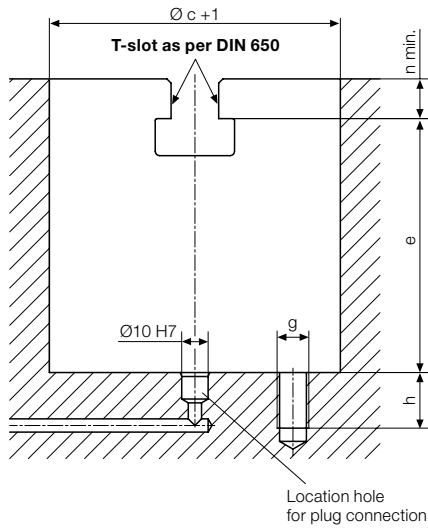

Technical data

Max. operating pressure 400 bar

For T-slot as per DIN 650		18	22	28
Clamping force at 400 bar	[kN]	55.2	76	144
Clamping force at 100 bar	[kN]	13.8	19	36
Piston Ø l	[mm]	70	80	105
Piston rod Ø d H7/f7	[mm]	56	63	80
Stroke	[mm]	6	6	6
Oil volume clamping	[cm ³]	9	12	22
Oil volume unclamping	[cm ³]	23	30	52
a	[mm]	18	22	28
b	[mm]	30	37	46
c e8	[mm]	110	130	166
e	[mm]	96	106	110
f	[mm]	14	18	22
g	[mm]	M12	M16	M20
h	[mm]	21	23	27
k	[mm]	111	125	135
n	[mm]	15.5	19.5	25.5
o	[mm]	31.1	36.2	46.7
p ± 0.05	[mm]	15	15	15
Weight	[kg]	6.1	9.5	16.6

Connection lengthwise to the T-slot Part no. 2354060 2355060 2356060

Connection crosswise to the T-slot Part no. 2354065 2355065 2356065

Further sizes and special versions are available on request

Important notes!

Make sure that the T-slot of the clamping piston is subject to an axial load only. The T-nut must be in contact over its complete surface. Side loads must be avoided.

In view of the surface ratio of the pull clamps, only check valves having a minimum ratio of 3.5 : 1 may be used for maintaining the clamping force.

**Plug-in connector
for manifold-mounting connection
(included in the delivery)
Part no. 9210 132**

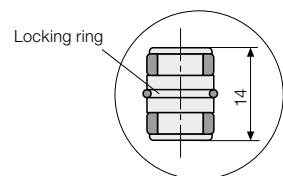

Location hole

