



Check list for the request for magnetic clamping systems

Machine tool

New machine **Machine manufacturer** _____

Retrofitting **Type** _____

Closing force _____

Opening force _____

Nozzle contact force (with open mould) _____

Ejection force (if required) _____

Temperature range

max. 80 °C **Mode of operation**

max. 120 °C horizontal

max. 180 °C vertical

max. 230 °C

max. 240 °C

Plate geometry

Rectangle

Cross

another type
(Sketch)

A = _____ mm

B = _____ mm

a = _____ mm

b = _____ mm

Tools

Dimensions

Smallest mould/die _____ mm Weight _____ kg

Largest mould/die _____ mm Weight _____ kg

Steel type base plate 1.1730 or others _____
(base plate thickness min. 25 mm)

Remarks

No drawing of machine bed available!

Further comments _____

Cable lengths

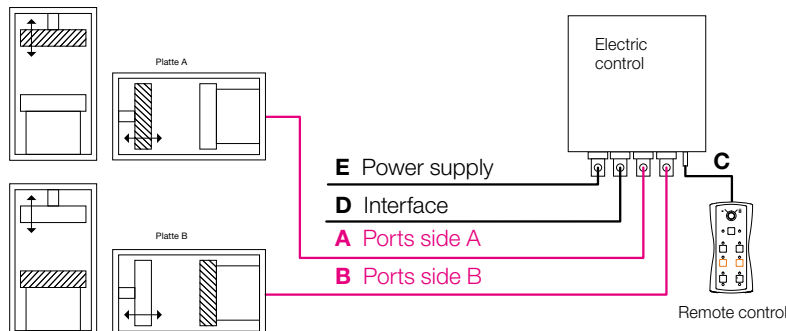

Desired cable length

A = _____ m

B = _____ m

C = _____ m

D = _____ m

E = _____ m