

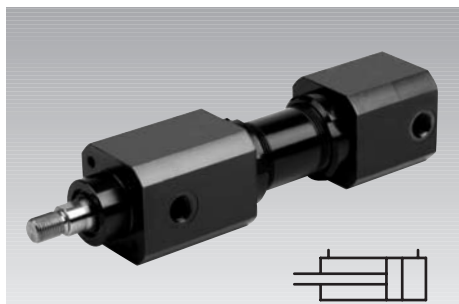

Hydro-Cylinder

with optional stroke end cushioning,
 double acting, max. operating pressure 200 bar



Hydro-cylinder without stroke end cushioning

Description

Double-acting hydro-cylinders with connecting dimensions according to DIN ISO 6020.

Only exception is the shorter overall length.

On request also available in the longer version as per DIN ISO 60 20.

The piston rod is provided with an external thread.

For fixing, the front and back part of the body is provided with 4 internal threads. The adjustable stroke end cushioning avoids a too hard stop of the piston in the cylinder body with the following applications:

1. High piston speed
2. Additional load at the piston rod
3. If an external stop cannot be provided to compensate the additional load.

Functioning - Stroke end cushioning

Just before the stroke end of the piston, the cushioning spigot enters into the cushioning disc and reduces the flow rate in the return line and thereby also the piston speed. The residual speed can be adjusted in certain limits by an adjustable flow control valve.

Material

Cylinder body: free-cutting steel, galvanized

Cylinder tube: HP tube

Piston rod: high alloy steel,
 chromium-plated

Seals: NBR or FKM

Important notes

When selecting the hydro-cylinder it is imperative to consider the maximum admissible lateral force and buckling load.

Operating conditions, tolerances and other data see data sheet A 0.100.

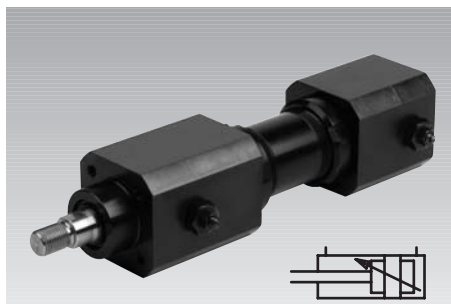

Hydro-cylinder with stroke end cushioning

Advantages

- Adjustable stroke end cushioning as an option
- Max. piston speed 0.5 m/s
- Low wear and friction Glydring seals
- High service life due to the use of guide rings at the piston and the piston rod
- Negligible leakage by double sealing piston rod
- Piston rod induction hardened and chromium-plated
- Effective wiper seal
- Self-centring cushioning discs with relief valve function for unthrottled cylinder start
- Fixing thread and centring spigot at both cylinder heads allow mounting of non standard accessories
- Particularly suitable for fixture building by direct mounting on cylinder head (small pitch circle dia.) and accurate centring
- Compact design

Accessories

Flange for fixing

The flange allows screwing on of the hydro-cylinder from the side of the cylinder (see figures on the right side).

Spherical bearing

As accessories the following spherical bearings can be delivered (see data sheet G 3.810).

A bearing block, which is fixed at the cylinder bottom with socket head cap screws.

A rod end bearing, which is screwed onto the external thread of the piston rod and then locked with the piston rod.

Fixing possibilities

● Flange mounting at front

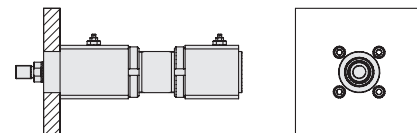

● Flange mounting at front with accessory flange

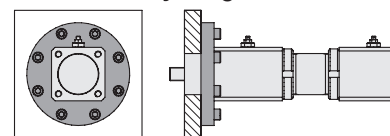

● Flange mounting at rear

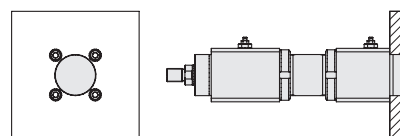

● Flange mounting at rear with accessory flange

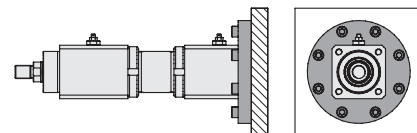

● With accessory spherical bearing

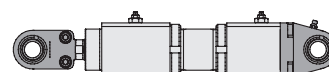

Hydraulic connecting possibilities

● Pipe thread

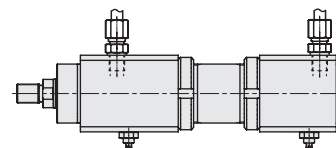

Dimensions Technical Characteristics

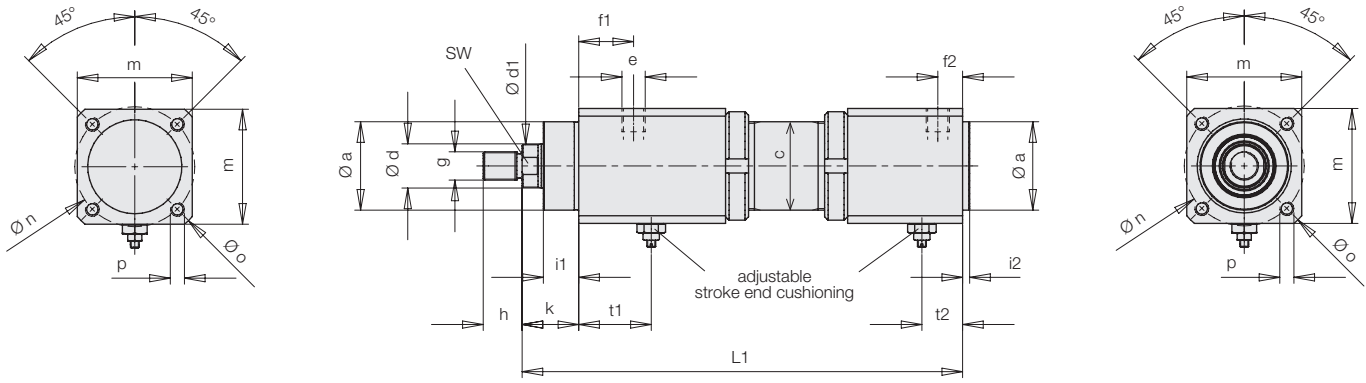

Piston Ø D	[mm]	25	32	40	50	63	80
Rod Ø d *)	[mm]	16	20	25	32	40	50
Nominal force	Forward thrust [kN]	9,8	16	25	39,2	62,3	100,5
	Pull thrust [kN]	5,7	9,8	15,3	23,1	37,2	61,2
Piston area	[cm ²]	4,91	8,04	12,56	19,63	31,17	50,26
Annulus area	[cm ²]	2,89	4,90	7,65	11,59	18,61	30,63
Cushioning stroke	[mm]	16	16	20	25	32	40
L	[mm]	38	44	52	65	80	97
L1 = stroke +	[mm]	108 (150)	121 (170)	149 (190)	162 (205)	189 (224)	226 (250)
L2 = stroke +	[mm]	120 (162)	137 (186)	165 (206)	182 (225)	214 (249)	258 (282)
L3 = stroke +	[mm]	140 (178)	162 (206)	195 (231)	219 (257)	259 (289)	313 (332)
Ø a f7	[mm]	32	40	50	60	70	85
Ø c	[mm]	35	42	50	60	75	95
Ø d1	[mm]	15	19	24	31	39	48,5
e		G 1/4	G 1/4 (3/8)	G 1/4 (1/2)	G 1/2	G 1/2 (3/4)	G 1/2 (3/4)
f1 *)	[mm]	21	22,5	31	34	41	46
f2 *)	[mm]	11	11	14	17	22	28
g	[mm]	M 12 x 1,25	M 14 x 1,5	M 16 x 1,5	M 20 x 1,5	M 27 x 2	M 33 x 2
h	[mm]	16	18	22	28	36	45
i1	[mm]	15	20 *)	20 *)	24	29	37 *)
i2	[mm]	3	3	4	4	4	4
k	[mm]	28	32	32	38	45	54
m *)	[mm]	50	55	65	80	95	115
Ø n	[mm]	45	58	68	82	95	115
Ø o *)	[mm]	61	73	86	104	119	144
p x depth of thread	[mm]	M 6 x 12	M 8 x 15	M 8 x 15	M 10 x 20	M 12 x 20	M 16 x 28
Ø r	[mm]	90	110	125	150	170	195
s	[mm]	12	16	16	20	25	32
t1	[mm]	25	29	41	44	54	60
t2	[mm]	15	17	23	27	35	42
Ø u	[mm]	75	92	106	126	145	165
Ø v	[mm]	7	9	9	11	14	18
SW	[mm]	13	17	22	27	36	46
Minimum stroke ± 1.5	[mm]	70	70	60	70	80	80
Maximum stroke ± 1.5	[mm]	750	950	1200	1200	1200	1200

Important note:

For stroke selection consider buckling load and transverse force on page 3.

Dimensions in () as per DIN ISO 6020 available on request

Dimensions marked by *) are not as per DIN ISO 6020

Part-no.

1 2 9 X - 1 X - X X X X

Stroke in mm (example stroke = 85 mm: **0085**)

Attention: consider minimum and maximum stroke (see chart)

Overlengths on request

- 3** = piston Ø 25
- 4** = piston Ø 32
- 5** = piston Ø 40
- 6** = piston Ø 50
- 7** = piston Ø 63
- 8** = piston Ø 80

- 0** = seal made of NBR, without cushioning
- 1** = seal made of FKM, without cushioning
- 2** = seal made of NBR, with cushioning
- 3** = seal made of FKM, with cushioning

Example of ordering

Hydro-cylinder,
piston diameter = 32 mm,
with FKM seals,
without cushioning,
stroke = 85 mm

Part number: 1294-11-0085

Technical Characteristics Accessories

Admissible transverse force with extended piston rod

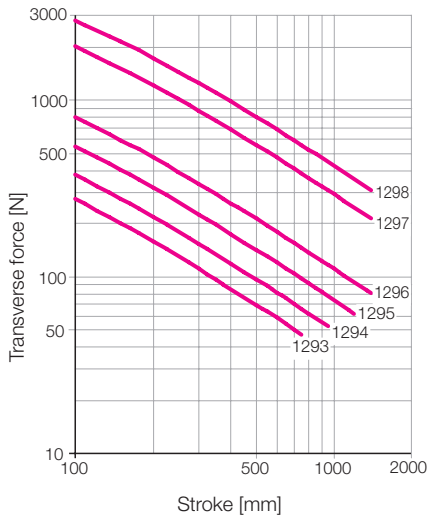
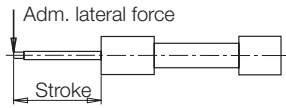

Buckling load Flange mounting at front

Limit values for stroke and operating pressures at buckling load (safety against buckling = 3.5)

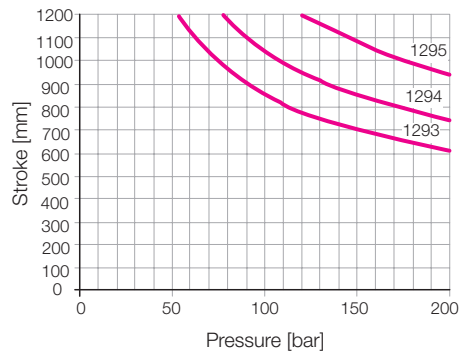
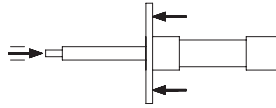

Buckling load Flange mounting at rear

Limit values for stroke and operating pressures at buckling load (safety against buckling = 3.5)

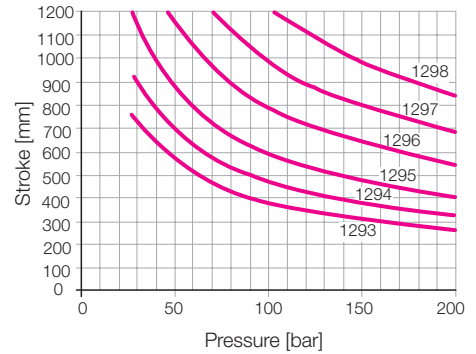
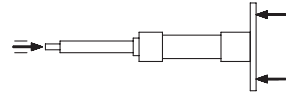

Important note:

Transverse forces have to be avoided, if possible, otherwise life of piston and piston rod guide are reduced.

Accessories

Flange for fixing

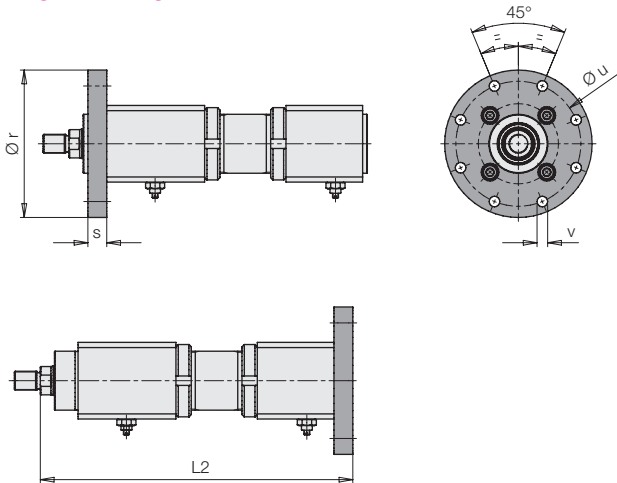

Spherical bearing

Dimensions, guide lines for application and other data see data sheet G 3.810.

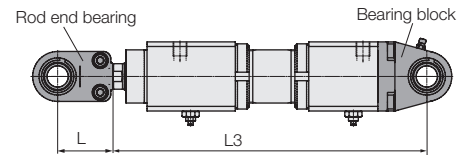

Buckling load for spherical bearings

Limit values for stroke and operating pressures at buckling load (safety against buckling = 3.5)

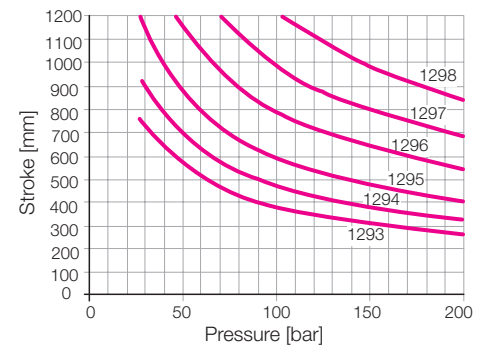

Part numbers for accessories

Size of hydro-cylinder	1293-	1294-	1295-	1296-	1297-	1298-
Flange	1283-910	1284-910	1285-910	1286-910	1287-910	1288-910
Rod end bearing	3890-023	3890-012	3890-017	3890-014	3890-018	3890-025
Bearing block	1293-940	1294-940	1295-940	1296-940	1297-940	1298-940