



**Hydraulic Threaded-Body Clamping Module**  
pull-type, single and double acting, with anti-torsion device  
max. operating pressure 500 bar



**Application**

The hydraulic threaded-body clamping module pull-type was developed for screwing in into:

- **standardized housings**  
(see page 2)
- **fixture bodies or manifold blocks**  
(see figure 2)
- **fixture base plates**  
or **intermediate plates for pallets**  
or **machine tool tables**  
(see page 2)

**Application examples**

Figure1 shows axial clamping of a workpiece in connection with a C-washer as per DIN 6371/6372. The hydraulic threaded-body clamping module is integrated in a standardized housing (dimensions see page 2). The C-washer (loose part) has to be attached for each clamping process.

When clamping with **elastomer spring elements** (see figure 2) the workpiece has to be centered by a shoulder at the location flange, since only axial and radial clamping forces can be introduced by the elastomer spring element.

When using **disks** (see figure 3) centring is provided by the disks as the axial and radial forces are applied.

The decision, which clamping element has to be used, depends on the tolerance of the workpiece and the required axial retention forces.

**Important notes**

Operating conditions and other data see data sheet A 0.100.

In single-acting applications, please pay attention to the instructions for bleeding of the spring area on data sheet A 0.110.

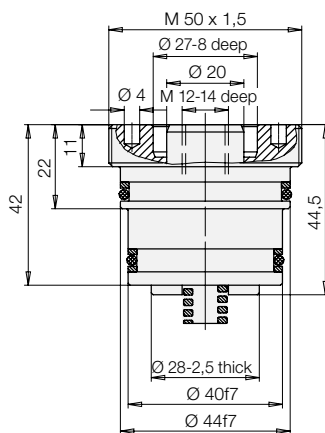
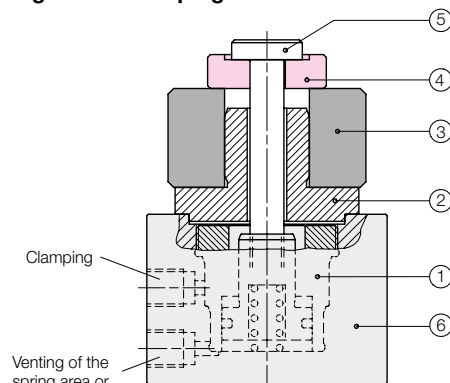
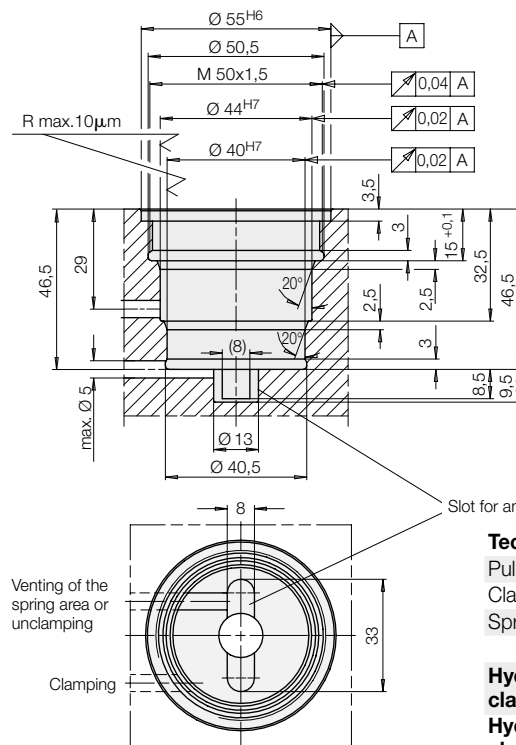

Figure 1 - Clamping with C-washer



- ① Clamping module
- ② Workpiece carrier
- ③ Workpiece
- ④ C-washer
- ⑤ Tie rod
- ⑥ Housing for clamping module

**Installation dimensions**



**Technical data**

Pulling force at 500 bar	[kN]	24.5
Clamping stroke, pulling	[mm]	6.0
Spring force	[N]	80-200

**Part no.**

<b>Hydraulic threaded-body clamping module</b>	<b>1574-811</b>
<b>Hydraulic threaded-body clamping module with housing</b>	<b>1574-812</b>
(see page 2)	

Figure 2 - Clamping with elastomer spring element

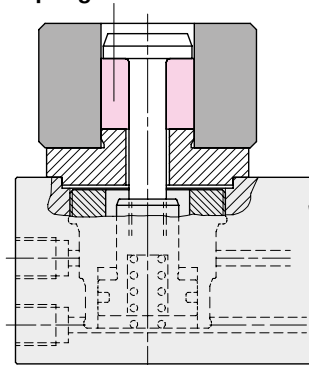
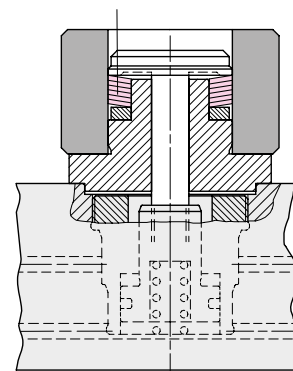
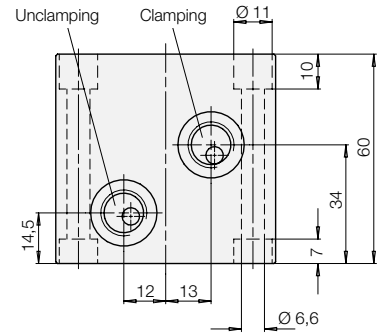
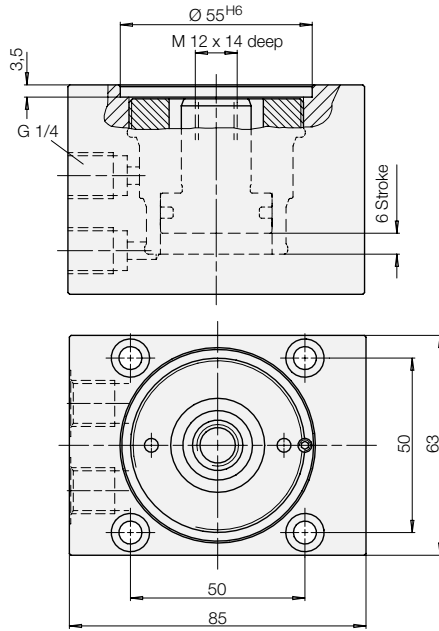

Figure 3 - Clamping with disk



## Dimensions Application example

### Hydraulic threaded-body clamping module with housing



<b>Hydraulic threaded-body clamping module with housing</b>	<b>Part no. 1574-812</b>
---	--------------------------

### Application example



### Installation of hydraulic clamping modules in the base plate of a multiple clamping fixture.

Transmission of the clamping force is made by an elastomer spring element  $\varnothing 50 \times \varnothing 17 \times 32$  mm high. The workpieces are centred by the shoulder at the flange.

In such an arrangement for clamping neither a wrench is required nor a C-washer has to be handled.