

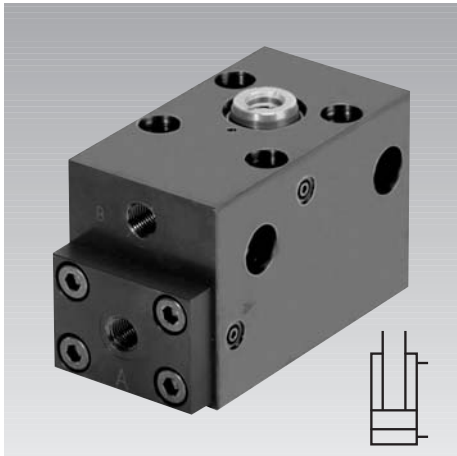

Clamping and Supporting Element self-locking, double acting, max. operating pressure 300 bar



Advantages

- Clamping and support function in one element
- Self-locking wedge clamping
- Re-clamping with hydraulic pressure
- High clamping safety also in case of sudden pressure drop
- Cushioning of vibration
- Interchangeable contact bolts
- Many fixing possibilities
- Oil supply optionally by fittings or through drilled channels
- Standard FKM seals
- Maintenance free

Function

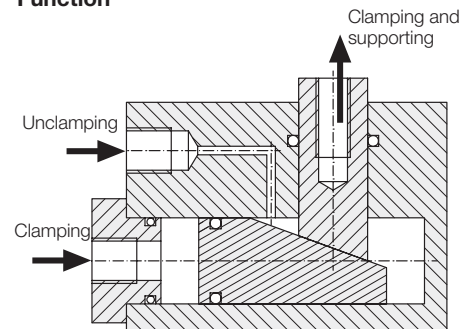

Application

The piston of traditional clamping cylinders is pushed back, if the counter force is bigger than the hydraulic clamping force. This is due to the compressibility of the hydraulic oil and the expansion of hydraulic hoses.

In the case of the clamping and supporting element this elasticity is avoided by the wedge-shaped cross piston with its self-locking geometry. Due to this fact there are the following possibilities of application:

- Workpieces must be firmly clamped even in case of a pressure drop in the hydraulic system
- Ribbings or webs of workpieces must be clamped by opposite clamping elements in a neutral position and then immovably locked.
- The machining forces are relatively high and directed against the clamping force
- Vibrations in the workpiece have to be cushioned

For all applications:

If the workpiece yields or the contact bolt digs deeper into the material due to machining forces or vibrations, the clamping and supporting element re-clamps provided that sufficient clamping pressure is available.

Important notes

- The clamping bolt is protected against torsion, but cannot compensate a permanent torque during operation.
- The clamping and supporting element is not suitable for the use as pull-type cylinder.
- If the clamping and supporting element is uncoupled from oil supply after clamping, e.g. on pallets, we recommend to install an accumulator in order to guarantee a re-clamping effect.
- Further operating conditions, tolerances and other data see data sheet A 0.100.

Description

The clamping and supporting element is a hydraulic clamping cylinder with mechanical locking according to the wedge principle.

Forces which are directed against the clamping force, e.g. machining forces will be supported with a negligible elasticity of the wedge-shaped piston. The counter force must not exceed the max. clamping force (see chart).

The clamping bolt is equipped with an interior thread to screw-in contact bolts for height adjustment or adapted contact bolts for shape adjustment.

The housing allows different fixing and connecting possibilities.

Oil supply is made at the front face with fittings or optionally through drilled channels with O-ring sealing at both sides or at the bottom.

Fixing possibilities

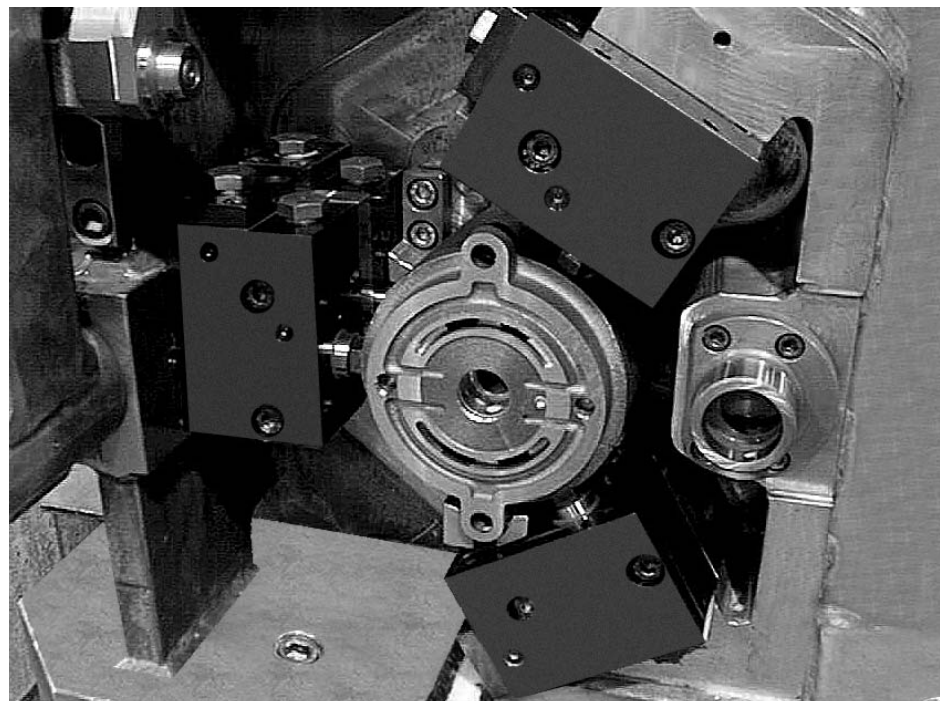
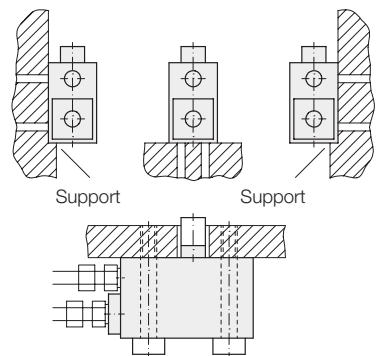

Dimensions Technical characteristics

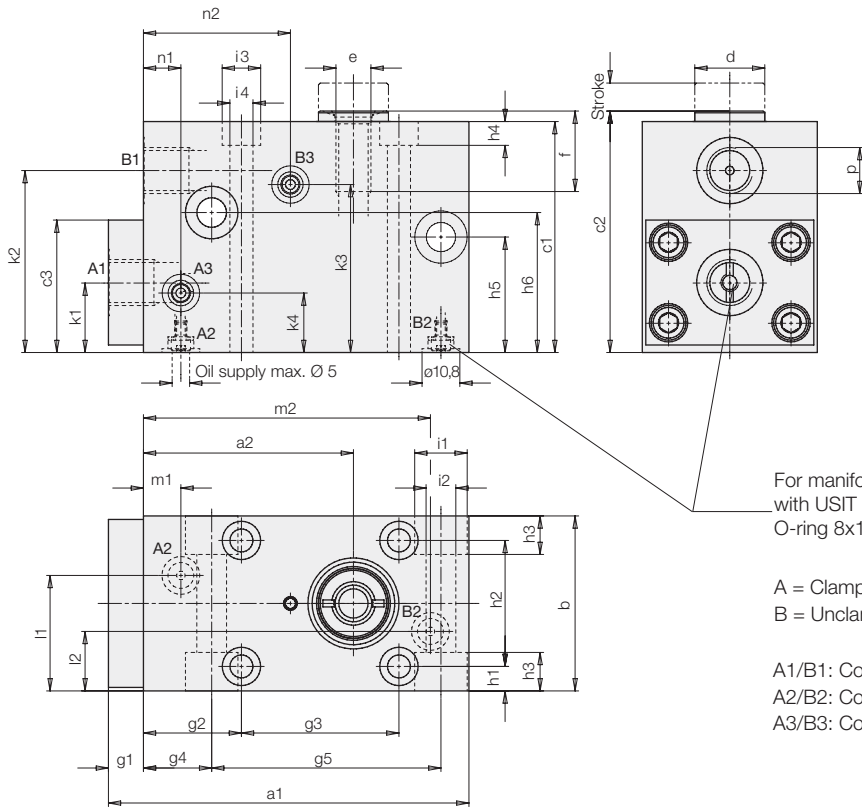

For manifold mounting remove socket head cap screws with USIT rings and screw-in 2 plugs G 1/4.
O-ring 8x1.5, see accessories

A = Clamping
B = Unclamping

A1/B1: Connection for fittings
A2/B2: Connection with O-rings at the bottom
A3/B3: Connection with O-rings at both sides

Clamping force *	[kN]	5	12	18
Max. operating pressure	[bar]	300	300	300
Oil volume clamping	[cm ³]	2.8	10.8	26.5
Oil volume unclamping	[cm ³]	2.2	8.3	22
Stroke	[mm]	5	8	12
a1	[mm]	85	103	127
a2	[mm]	47.2	60	71
b	[mm]	40	50	64
c1	[mm]	45	66	78
c2	[mm]	48	69	81
c3	[mm]	45	37.9	47.5
Ø d	[mm]	12	20	22
e	[mm]	M5	M10	M12
f	[mm]	10	23	24
g1	[mm]	15	10	12
g2	[mm]	24.5	28	41
g3	[mm]	39	45	44
g4	[mm]	24.5	28	26
g5	[mm]	39	57	75
h1	[mm]	6.5	7	9
h2	[mm]	27	36	46
h3	[mm]	11.5	11	11
h4	[mm]	12	6.8	9
h5	[mm]	38.5	40	52
h6	[mm]	8	40	52
Ø i1	[mm]	10.5	15	18
Ø i2	[mm]	6.5	8.5	10.5
Ø i3	[mm]	9.5	11	15
Ø i4	[mm]	5.5	6.6	8.5
k1	[mm]	18	20	25
k2	[mm]	36.5	52	64
k3	[mm]	10	52	64
k4	[mm]	22	20	25
l1	[mm]	25	33	40
l2	[mm]	16	17	24
m1	[mm]	9.7	10.7	10.7
m2	[mm]	60.5	85	105.5
n1	[mm]	9.7	10.7	10.7
n2	[mm]	44.2	42	52
P		G1/8*	G 1/4	G 1/4

* Use fittings DL6 DIN2353.

Part-no.	1915-100	1915-300	1915-400
Accessories (not included in the delivery)			
O-ring (FKM) 8x1.5	3000-275	3000-275	3000-275
Screw-in plug	3610-047	3300-821	3300-821
Alternatively			
Plug (flush screwable)	0361-986	0361-987	0361-987
Contact bolt	3614-027	3614-002	3614-028

Clamping force and unclamping pressure

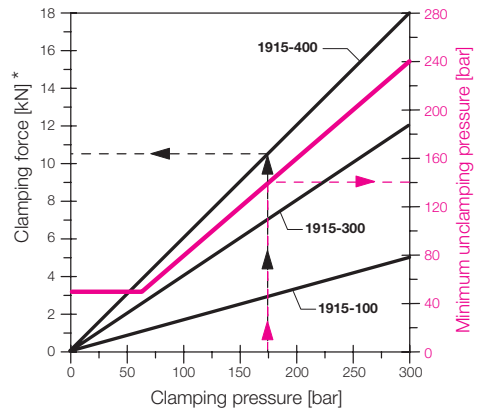

Example:

Clamping and supporting element	1915-400
Clamping pressure	175 bar
Clamping force	10.5 kN
Min. unclamping pressure	140 bar

*Important note

With the wedge principle the effective clamping force depends on the friction of the sliding surfaces. After several thousand operations with load a smoothing of these sliding surfaces can be noticed, that reduces considerably the adhesion factor and can increase the clamping force up to 75%. Therefore the indicated clamping forces are minimum values. For unclamping the self-locking of the wedge clamping must be overcome. That is the reason why the minimum unclamping pressure must be at least 80% of the applied clamping pressure.