



## Block Clamps

### Versions with / without self-locking

double acting, max. operating pressure 70 / 100 bar



#### Advantages

- Large retention force
- Flat design
- Clamping in small recesses and bore holes
- Suitable for machining from 5 sides
- 2 sizes with and without self-locking available
- Low pressure allows direct connection to the hydraulic system of the machine
- Contact bolts exchangeable
- Clamping direction 0 to 360° adjustable
- Alternatively pipe connection or manifold-mounting connection

#### Application

Hydraulic block clamps are particularly suitable for clamping of workpieces, that require a large free space for machining, and for applications where conventional clamps and swing clamps are too big.

Especially for the machining from five sides the reduced height of the block clamp and the possibility to immerge into a horizontal bore hole for clamping are of special advantage.

The block clamp with self-locking is preferably used on clamping pallets, that will be disconnected from the pressure generator after clamping.

The low operating pressure of 70 and/or 100 bar allows the direct connection to the low-pressure hydraulics of many machining machines.

#### Important notes

Block clamps must only be used for clamping of workpieces in industrial applications and may only be operated with hydraulic oil. They generate very high forces. The workpiece, the fixture or the machine must be in the position to compensate these forces. In the effective area of the clamping bolt there is the danger of crushing. The manufacturer of the fixture or the machine is obliged to provide effective protection devices.

#### Operating instructions

When mounting the block clamp pay attention to careful bleeding (see page 2). The clamping bolt must effect its linear stroke to the clamping point without any impediments in order to avoid damages of the mechanics or at the workpiece. In extended position, the clamping bolt is not protected against torsion so that the contact bolt can adapt itself to the workpiece contour. In retracted position, the clamping bolt is turned back again to the angle position previously adjusted at the cover, if the deviation is smaller than  $\pm 8^\circ$  (see also page 2).

Operating conditions, tolerances and other data see data sheet A 0.100.

#### Description

Block clamps are double acting hydraulic cylinders. The clamping bolt is supported by a ball bearing and can be swivelled. During the linear extending stroke the clamping bolt with the contact bolt is moved above the clamping point and then swivelled onto the clamping point by means of a wedge drive.

The version without self-locking has a smooth wedge surface and requires a constantly available oil pressure.

In the version with self-locking, the wedge drive is provided with a tothing to increase the factor of friction. Thus the clamping force is considerably smaller, but is maintained in the case of a pressure drop.

By twisting the clamping bolt together with the rear bottom cover every desired angle position can be adjusted (see also page 2).

#### Effective clamping force

The clamping force is generated by a wedge drive and therefore depends on the friction of the sliding surfaces. The friction coefficient is not constant over the entire service life. At the beginning it is a little higher, i.e. the clamping force does not yet attain the set value. With increasing stroke cycles, the friction surfaces become smoother and the clamping force increases slowly. After some hundred thousand operations, the effective clamping force can exceed the nominal value by 10 to 30 % (see chart).

This characteristic of wedge drives must be taken into consideration for the fixture design, i.e.

1. The reduced clamping force in new condition must be sufficient for safe clamping of the workpiece.
2. With increasing clamping force the workpiece must not be inadmissibly deformed.

Conclusion: If an exactly reproducible clamping force is required, conventional clamping elements with direct piston drive must be used.

#### Position monitoring

Versions with extended piston rod at the back and pneumatic position monitoring are available on request.

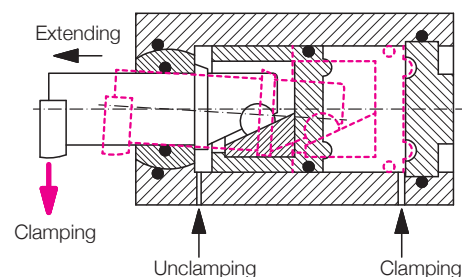
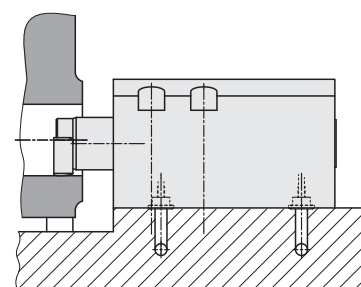

#### Clamping force diagram

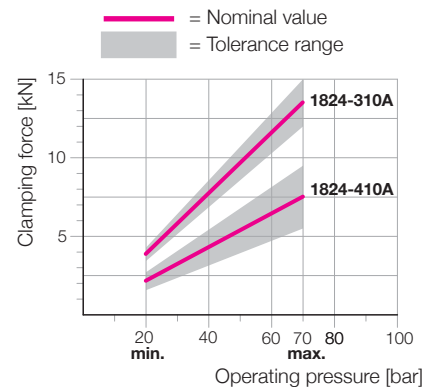

1824-310A without self-locking

1824-410A with self-locking

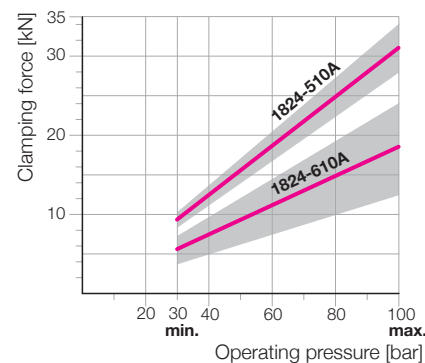

1824-510A without self-locking

1824-610A with self-locking

# Dimensions

## Technical characteristics • Clamping direction

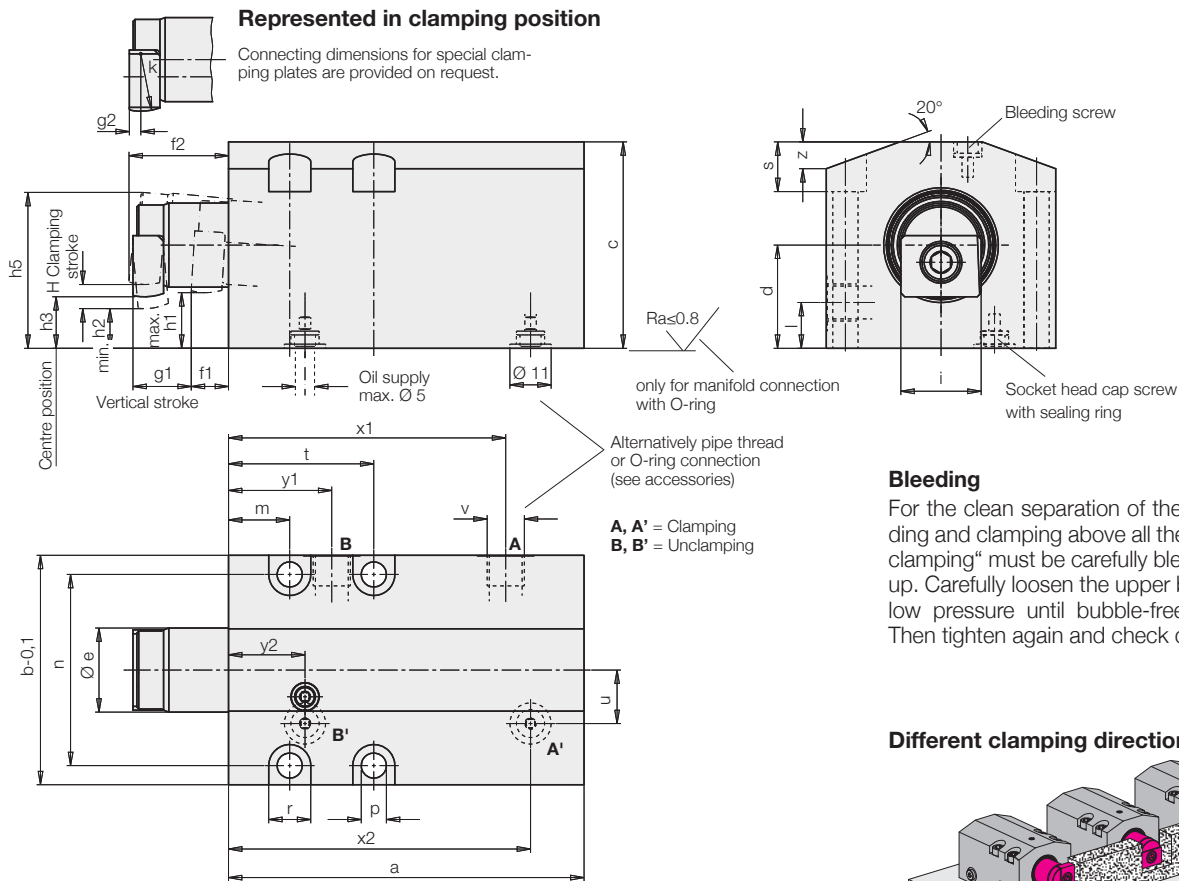

### Bleeding

For the clean separation of the functions extending and clamping above all the connection „unclamping“ must be carefully bled during the start up. Carefully loosen the upper bleeding screw at low pressure until bubble-free oil comes out. Then tighten again and check density.

### Different clamping directions

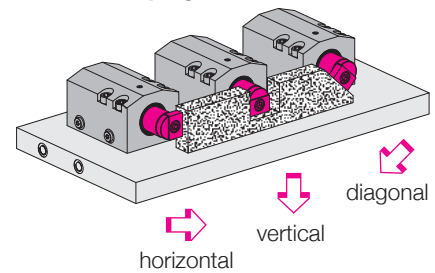

Clamping direction can optionally be in all directions vertically to the axis of the clamping lever. The clamping lever must be in retracted position and the cylinder cover must be rotated by the corresponding angle. When adjusting the clamping direction at the cover, it has to be considered that the clamping direction of the contact bolt goes in the same direction.

**Example:** 90° counterclockwise

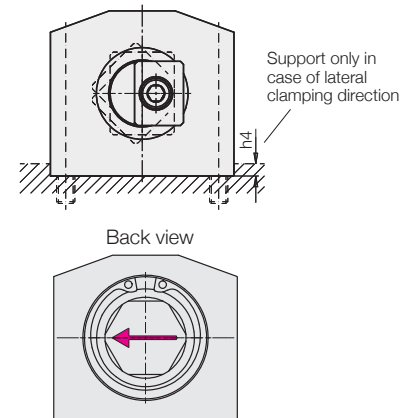

Claming function		without self-locking	with self-locking	without self-locking	with self-locking
Clamping force approx.*	[kN]	13.5	7.5	31	18.5
Max. operating pressure	[bar]	70	70	100	100
Min. operating pressure	[bar]	20	20	30	30
Oil volume					
Clamping / Unclamping	[cm³]	28.9/22.8	28.9/22.8	102/76.4	102/76.4
H max. clamping stroke.	[mm]	6	6	8	8
a	[mm]	93	93	126	126
b -0,1	[mm]	60	60	88	88
c	[mm]	54	54	75	75
d	[mm]	27	27	37.5	37.5
Ø e	[mm]	22	22	35	35
f1	[mm]	10	10	13	13
f2	[mm]	26	26	40.5	40.5
g1	[mm]	15	15	26	26
g2	[mm]	3	3	3	3
h1	[mm]	14	14	19	19
h2	[mm]	11	11	15	15
h3	[mm]	13.5	13.5	18.5	18.5
h4	[mm]	4	4	6	6
h5	[mm]	41	41	60	60
i	[mm]	21	21	34	34
k	[mm]	15	15	25	25
l	[mm]	12	12	13	13
m	[mm]	16	16	21	21
n	[mm]	50	50	72	72
p	[mm]	6.6	6.6	11	11
r	[mm]	11	11	18	18
s	[mm]	13	13	20	20
t	[mm]	38	38	53	53
u	[mm]	14	14	15	15
v		G 1/8	G 1/8	G 1/4	G 1/4
x1	[mm]	72.5	72.5	99	99
x2	[mm]	79	79	108	108
y1	[mm]	27	27	37	37
y2	[mm]	20	20	28	28
z	[mm]	7	7	10	10
<b>Part-no.</b>		<b>1824-310A</b>	<b>1824-410A</b>	<b>1824-510A</b>	<b>1824-610A</b>

\* Effective clamping force see page 1

### Accessories:

Accessories:	Part-no.
O-ring 8 x 1.5	<b>3000-343</b>
Screw plug G 1/8	<b>3610-047</b>
Screw plug G 1/4	<b>3300-821</b>