

## Mini Hinge Clamp with metallic wiper edge, double acting, max. operating pressure 250 bar

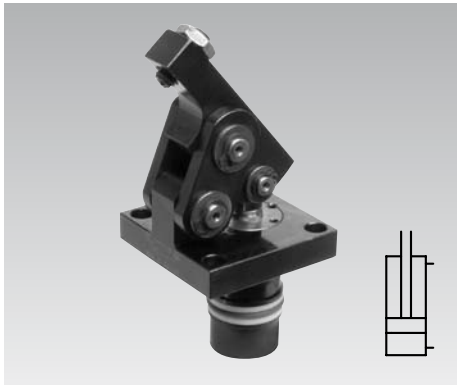

### Advantages

- Compact design
- Body partially recessible
- Oil supply through drilled channels
- Unimpeded loading and unloading of the fixture when using clamping levers with swivel contact bolt
- Clamping lever can be swivelled into small recesses
- Clamping possible without side loads
- Two different clamping levers are available
- Long clamping lever adaptable to the workpiece
- Lever mechanism easy to clean
- Standard metallic wiper edge
- Standard FKM seals
- Mounting position: any

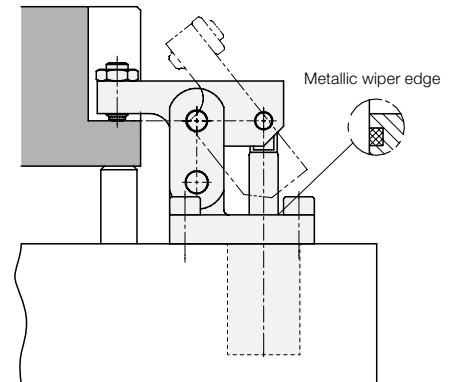

### Application

The mini hinge clamp is a low-cost hydraulic clamping element for thin-walled workpieces and reduced space.

The special kinematics allow clamping nearly without side loads of workpieces which are very sensitive against deformation.

A clamping recess in the workpiece a little bit wider than the clamping lever is sufficient as clamping surface.

### Description

When pressurising the element, the piston moves upwards and swivels the clamping lever over the hinges forwards and at the same time downwards onto the workpiece. The piston force is deviated by 180° and is available as clamping force with virtually no loss of efficiency.

During unclamping the clamping lever with swivel contact bolt will be swivelled behind the front edge of the flange, thereby unimpeded loading and unloading of the workpiece is possible.

Workpieces which are very sensitive against deformation are clamped nearly without cross loads, if the clamping surface is at the height of the bearing pins of the clamping lever (34 mm above the flange surface, see page 2).

The optionally available long clamping lever is provided for customer-specific adaptations.

### Important notes

Hinge clamps must only be used for clamping of workpieces in industrial applications and may only be operated with hydraulic oil.

Hinge clamps can generate very high forces. The workpiece, the fixture or the machine must be in the position to compensate these forces.

Considerable injuries can be caused to fingers during clamping and unclamping in the effective area of the clamping lever.

The manufacturer of the fixture or the machine is obliged to provide effective protective measures.

Hinge clamps have to be checked regularly on contamination by swarf and have to be cleaned. Operating conditions, tolerances and other data see data sheet A 0.100.

### Installation and connecting possibilities

**Cartridge type**  
for horizontally-drilled channels

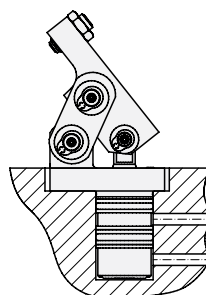
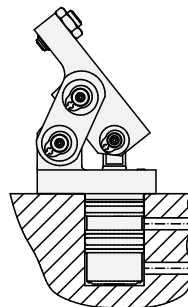

### Application example

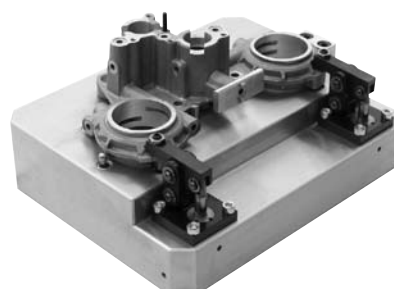

### Options for clamping levers

**Clamping lever with swivel contact bolt**

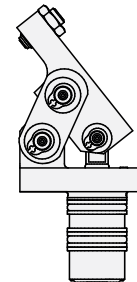

**Long clamping lever**

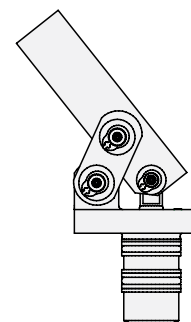

**without clamping lever**

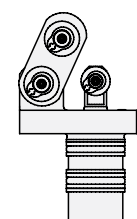

# Dimensions Technical characteristics

## Without clamping lever 1825-010

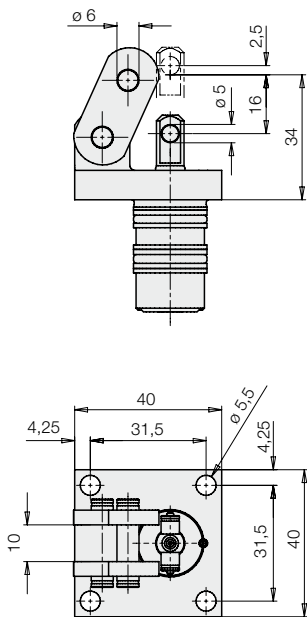

### Technical characteristics

Clamping force	[kN]	2.2
Max. operating pressure	[bar]	250
Min. operating pressure	[bar]	10
Oil volume Clamping	[cm <sup>3</sup> ]	2.1
Unclamping	[cm <sup>3</sup> ]	1.2
Max. flow rate		
Clamping	[cm <sup>3</sup> /s]	15
Unclamping	[cm <sup>3</sup> /s]	8
Weight		
<b>1825-010</b>	[kg]	0.23
<b>1825-011</b>	[kg]	0.28
<b>1825-012</b>	[kg]	0.32

### Calculations

1. Length L of clamping lever is known

1.1 Admissible operating pressure

$$p_{adm} = \frac{B}{\frac{C}{L} + 1} \leq 250 \quad [\text{bar}]$$

1.2 Effective clamping force

$$p_{adm} > 250 \text{ bar} \rightarrow F_{Sp} = \frac{A}{L} * 250 \quad [\text{kN}]$$

$$p_{adm} < 250 \text{ bar} \rightarrow F_{Sp} = \frac{A}{L} * p_{adm} \quad [\text{kN}]$$

2. Min. length of clamping lever

$$L_{min.} = \frac{C}{\frac{B}{p} - 1} \quad [\text{mm}]$$

L, L<sub>min.</sub> = Length of clamping lever [mm]

p, p<sub>adm</sub> = Operating pressure [bar]

A, B, C = Constants as per chart

### Constant 1825-0

A	0.199
B	449.716
C	17.575

## Clamping lever with contact bolt 1825-011

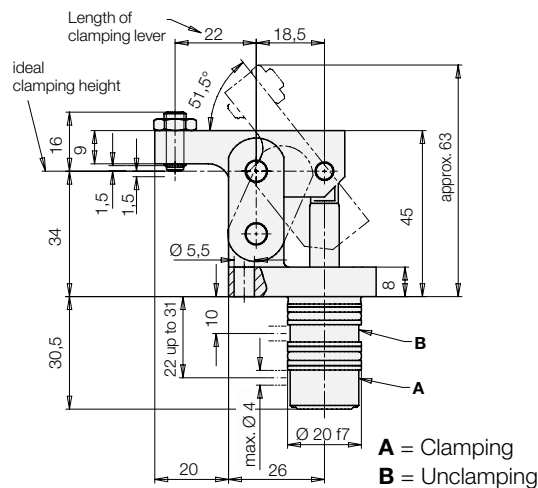

### Location hole

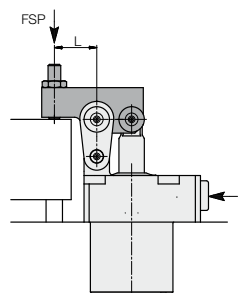
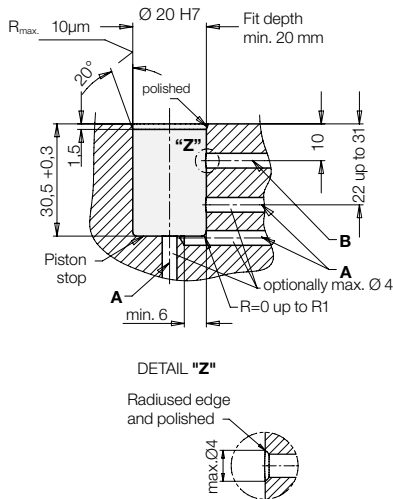

### Clamping force diagram

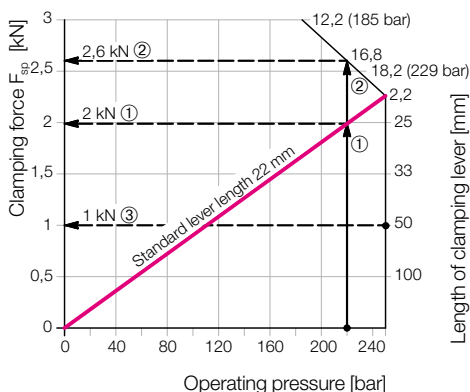

## Long clamping lever 1825-012

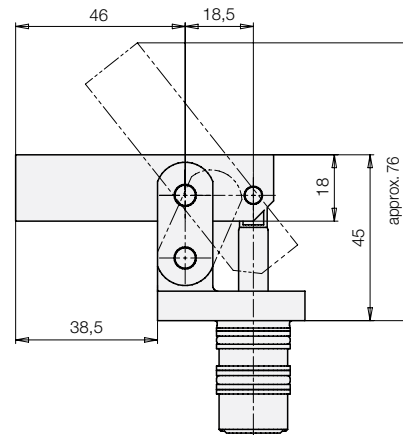

### Connecting dimensions for self-manufactured clamping levers

Material: C45 + C (1.0503)

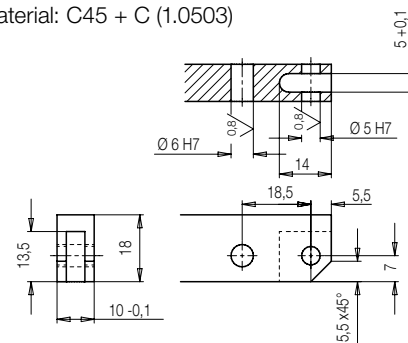

### Example 1: Hinge clamps 1825-011

Operating pressure 220 bar

Standard clamping lever L = 22 mm

### Effective clamping force

$$F_{Sp} = \frac{A}{L} * p = \frac{0.199}{22} * 220 = 2 \text{ kN}$$

### Example 2: Hinge clamps 1825-010

Operating pressure 220 bar

### Min. length of clamping lever

$$L_{min.} = \frac{C}{\frac{B}{p} - 1} = \frac{17.575}{\frac{449.716}{220} - 1} = 16.8 \text{ mm}$$

### Effective clamping force

$$F_{Sp} = \frac{A}{L} * p = \frac{0.199}{16.8} * 220 = 2.6 \text{ kN}$$

### Example 3: Hinge clamps 1825-010

Special clamping lever L = 50 mm

### Admissible operating pressure

$$p_{adm} = \frac{B}{\frac{C}{L} + 1} = \frac{449.716}{\frac{17.575}{50} + 1} = 332 > 250 \text{ bar}$$

### Effective clamping force

The max. operating pressure is 250 bar, thus

$$F_{Sp} = \frac{A}{L} * 250 = \frac{0.199}{50} * 250 = 1 \text{ kN}$$