

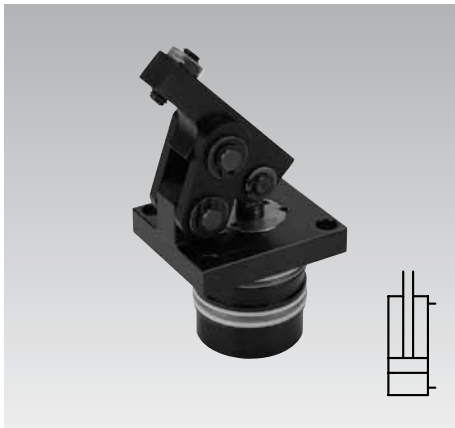

Mini Hinge Clamps 70 bar
with metallic wiper edge,
double acting, max. operating pressure 70 bar



Advantages

- High clamping force at low operating pressure
- Compact design
- Body partially recessible
- Oil supply through drilled channels
- Unimpeded loading and unloading of the fixture when using clamping levers with swivel contact bolt
- Clamping possible without side loads
- Two different clamping levers are available
- Long clamping lever adaptable to the workpiece
- Lever mechanism easy to clean
- Standard metallic wiper edge
- Standard FKM seals
- Mounting position: any

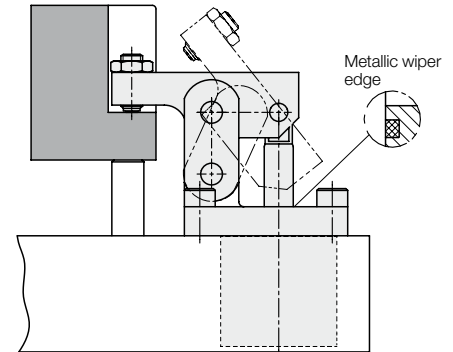

Application

The mini hinge clamp is a low-cost hydraulic clamping element for thin-walled workpieces and reduced space.

The special kinematics allow clamping nearly without side loads of workpieces which are very sensitive against deformation.

A clamping recess in the workpiece a little bit wider than the clamping lever is sufficient as clamping surface.

This line is designed for the direct connection to the machine hydraulics with a max. operating pressure of 70 bar.

Description

When pressurising the element, the piston moves upwards and swivels the clamping lever over the hinges forwards and at the same time downwards onto the workpiece. The piston force is deviated by 180° and is available as clamping force with virtually no loss of efficiency. During unclamping the clamping lever with swivel contact bolt will be swivelled behind the front edge of the flange, thereby unimpeded loading and unloading of the workpiece is possible.

Workpieces which are very sensitive against deformation are clamped nearly without cross loads, if the clamping surface is at the height of the bearing pins of the clamping lever (34 mm above the flange surface, see page 2).

The optionally available long clamping lever is provided for customer-specific adaptations.

Important notes

Hinge clamps must only be used for clamping of workpieces in industrial applications and may only be operated with hydraulic oil.

Hinge clamps can generate very high forces. The workpiece, the fixture or the machine must be in the position to compensate these forces.

Considerable injuries can be caused to fingers during clamping and unclamping in the effective area of the clamping lever.

The manufacturer of the fixture or the machine is obliged to provide effective protective measures. Hinge clamps have to be checked regularly on contamination by swarf and have to be cleaned. Operating conditions, tolerances and other data see data sheet A 0.100.

Installation and connecting possibilities

Cartridge type

for horizontally-drilled channels

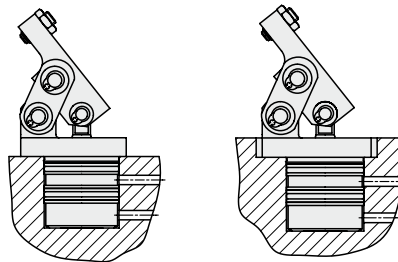

Options for clamping levers

Clamping lever with swivel contact bolt

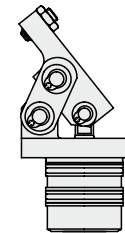

Long clamping lever

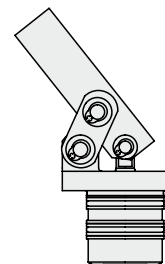

without clamping lever

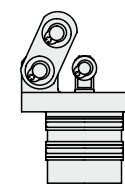

Application example

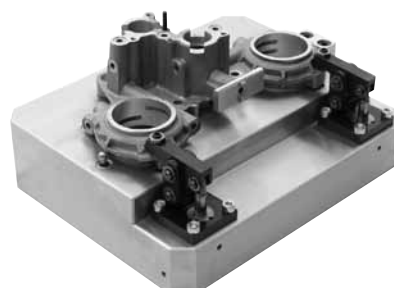

Dimensions Technical characteristics

Without clamping lever 1826-010

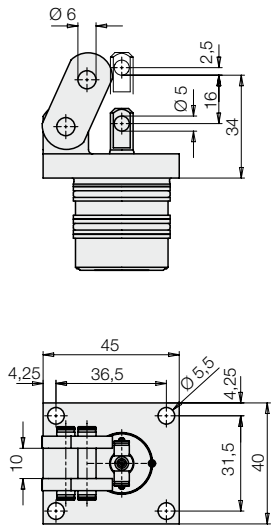

Clamping lever with contact bolt 1826-011

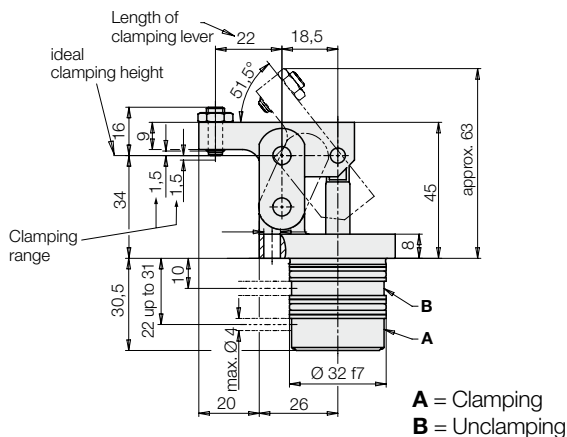

Long clamping lever 1826-012

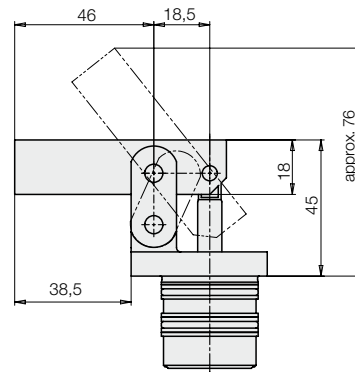

Technical characteristics

Clamping force	[kN]	2.3
Max. operating pressure	[bar]	70
Min. operating pressure	[bar]	10
Oil volume	[cm³]	7.7
Unclamping	[cm³]	6.8
Max. flow rate	[cm³/s]	15
Clamping	[cm³/s]	15
Unclamping	[cm³/s]	15
Weight	[kg]	0.30
1826-010		
1826-011	[kg]	0.35
1826-012	[kg]	0.39

Calculations

1. Length L of clamping lever is known

1.1 Admissible operating pressure

$$p_{adm} = \frac{B}{\frac{C}{L} + 1} \leq 70 \quad [\text{bar}]$$

1.2 Effective clamping force

$$p_{adm} > 70 \text{ bar} \rightarrow F_{Sp} = \frac{A}{L} * 70 \quad [\text{kN}]$$

$$p_{adm} < 70 \text{ bar} \rightarrow F_{Sp} = \frac{A}{L} * p_{adm} \quad [\text{kN}]$$

2. Min. length of clamping lever

$$L_{min.} = \frac{C}{\frac{B}{p} - 1} \quad [\text{mm}]$$

L, L_{min.} = Length of clamping lever [mm]

p, p_{adm} = Operating pressure [bar]

A, B, C = Constants as per chart

Constant 1826-01

A	0.73
B	125.92
C	17.575

Location hole

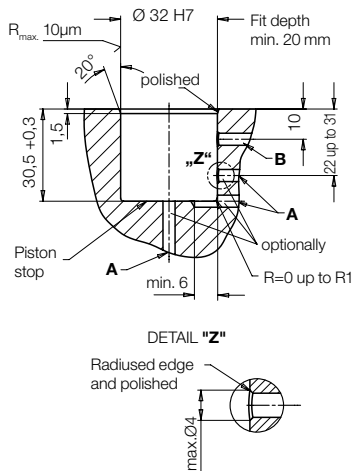

Connecting dimensions for self-manufactured clamping levers

Material: C45 + C (1.0503)

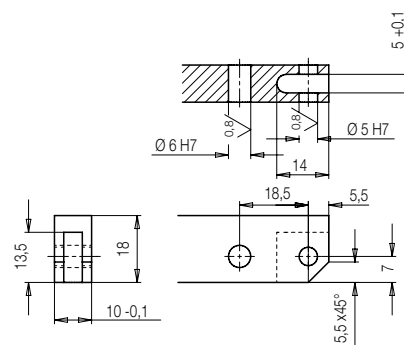

Example 1: Hinge clamps 1826-011
Operating pressure 60 bar
Standard clamping lever L = 22 mm

Effective clamping force

$$F_{Sp} = \frac{A}{L} * p = \frac{0.73}{22} * 60 = 2 \text{ kN}$$

Example 2: Hinge clamps 1826-010

Operating pressure 60 bar

Min. length of clamping lever

$$L_{min.} = \frac{C}{\frac{B}{p} - 1} = \frac{17.575}{\frac{125.92}{60} - 1} = 16 \text{ mm}$$

Effective clamping force

$$F_{Sp} = \frac{A}{L} * p = \frac{0.73}{16} * 60 = 2.7 \text{ kN}$$

Example 3: Hinge clamps 1826-010

Special clamping lever L = 51 mm

Admissible operating pressure

$$p_{adm} = \frac{B}{\frac{C}{L} + 1} = \frac{125.92}{\frac{17.575}{51} + 1} = 93.6 > 70 \text{ bar}$$

Effective clamping force

The max. operating pressure is 70 bar, thus

$$F_{Sp} = \frac{A}{L} * 70 = \frac{0.73}{51} * 70 = 1 \text{ kN}$$

Clamping force diagram

