

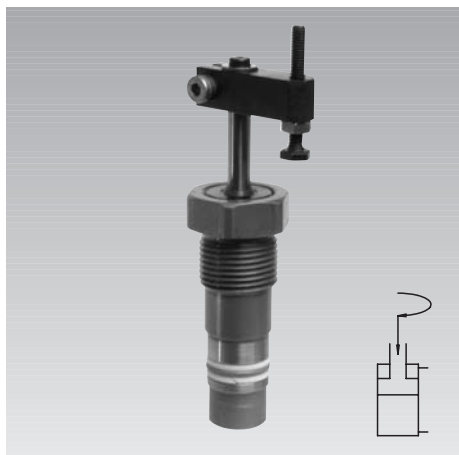

Mini Swing Clamps with Sturdy Swing Mechanism
threaded-body type,
double acting, max. operating pressure 150 bar



Advantages

- Minimum dimensions
- Double-acting function
- Sturdy swing mechanism
- Oil supply through drilled channels
- Built-in housing of tube connecting thread available
- Installation as cartridge type by accessory flange
- Simple fixing of clamping arm
- Clamping arm for clamping with minimum deformation available
- Unimpeded loading and unloading of the fixture
- Mounting position: variable
- Standard FKM seals
- Maintenance free

Clamping principle

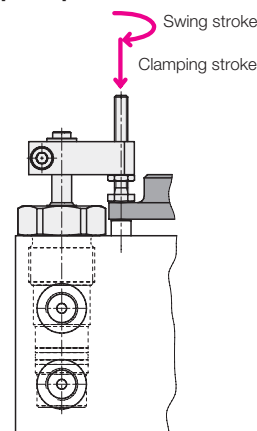

Application

Hydraulic swing clamps are used for clamping of workpieces, when it is essential to keep the clamping area free of straps and clamping components for unrestricted workpiece loading and unloading.

Mini swing clamps are particularly suitable for machining of thin-walled workpieces, which require only little clamping forces.

Mini swing clamps are an interesting alternative for pneumatic clamping elements, since they require less space.

Description

This double-acting mini swing clamp works as pull-type cylinder where a part of the total stroke is used to swing the piston.

Clockwise and counterclockwise versions are available with an swing angle of 90, 60 and 45 degrees. The 0 degree version can be used as push and pull-type cylinder with anti-rotation piston.

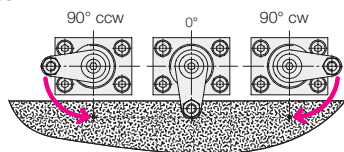

The clamping arms are locked on the piston rod. A safety screw avoids axial displacement.

Important notes

- Considerable injuries can be caused to fingers during clamping and unclamping in the effective area of the clamping arm. Remedy: protection device with electrical locking.
- Operating conditions, tolerances and other data see data sheet A 0.100.

Installation and connecting possibilities

Threaded-body type
for horizontally-drilled channels

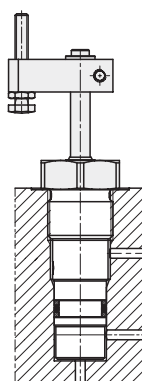

Pipe thread with accessory built-in housing

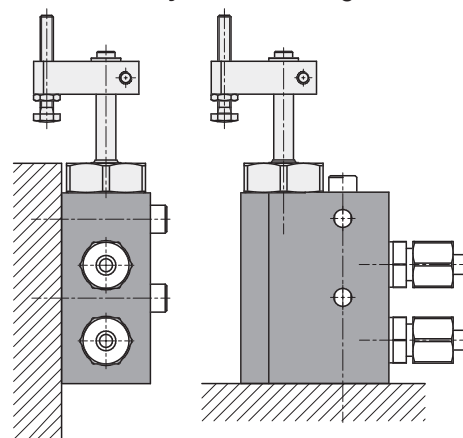

Installation as cartridge type with accessory fixing flange

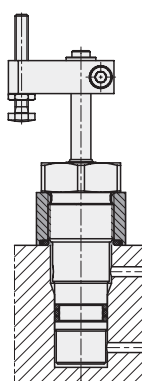

Threaded-body type with accessory clamping strap
for clamping with minimum deformation

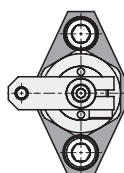
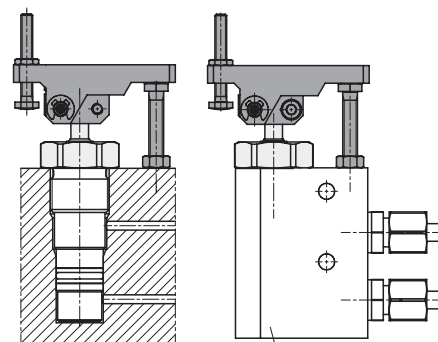

Accessory Built-in housing

Technical characteristics Dimensions • Accessories

Technical characteristics

Piston Ø	[mm]	10
Rod Ø	[mm]	6
Swing stroke	[mm]	10
Clamping stroke	[mm]	8
Total stroke	[mm]	18
Effective piston area		
Clamping	[cm ²]	0.5
Unclamping	[cm ²]	0.78
Required oil per stroke		
Clamping	[cm ³]	0.91
Unclamping	[cm ³]	1.42
Max. oil flow rate		
Clamping	[cm ³ /s]	6
Unclamping	[cm ³ /s]	10
Min. operating pressure	[bar]	25
Max. operating pressure	[bar]	150
Max. pulling force	[kN]	0.75
Effective clamping force	[kN]	see diagram
Weight	[kg]	0.12

Part numbers

Swing angle	Swing direction	Part-no.
90°	CW	1848-115
90°	CCW	1848-125
60°	CW	1848-135
60°	CCW	1848-145
45°	CW	1848-155
45°	CCW	1848-165
0°	-	1848-105

Clamping force diagram

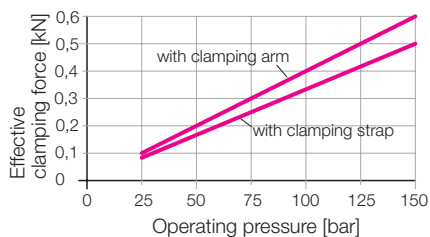

Dimensions

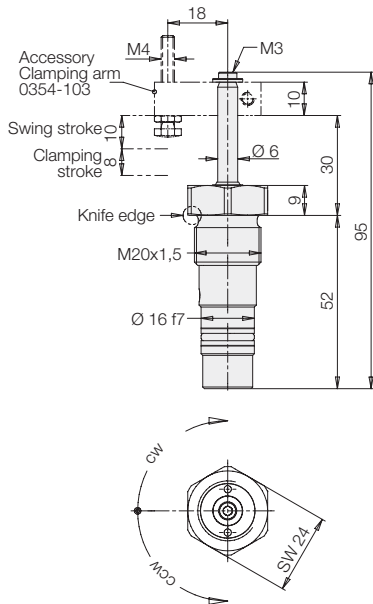

Accessory

Fixing flange 0354-410

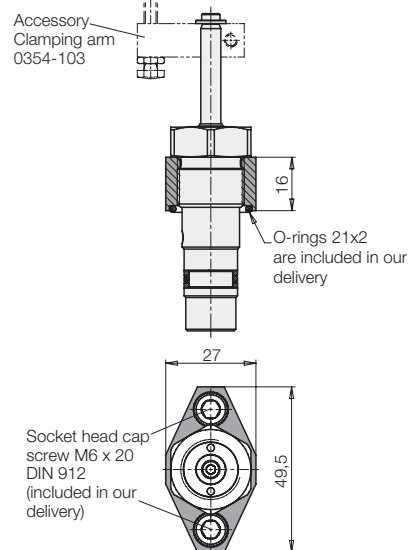

Porting details

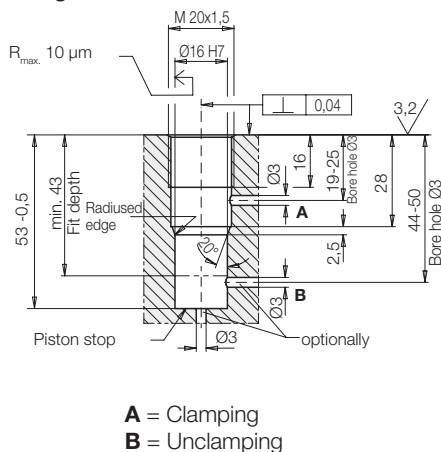

Cartridge-type hole

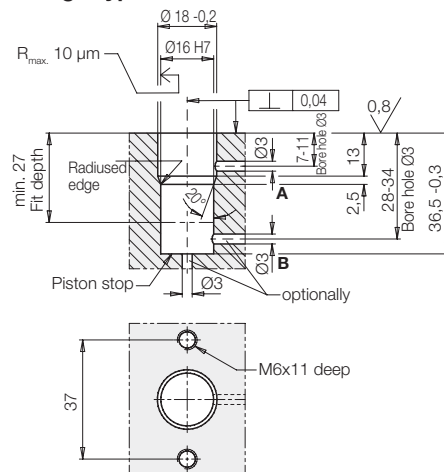

Accessory

Built-in housing 0346-710

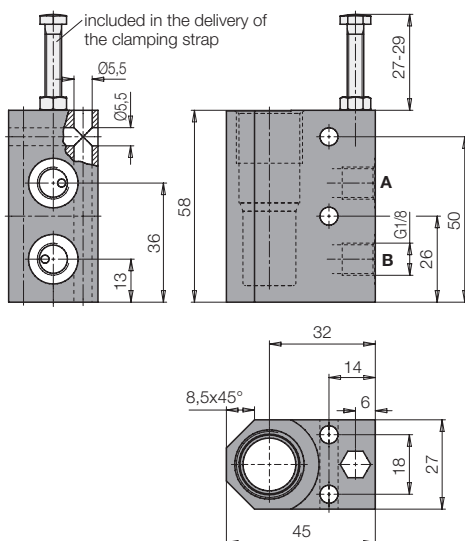

Accessory

Clamping arm 0354-103

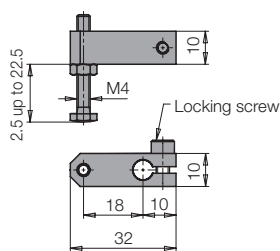

Dimensions for special clamping arms

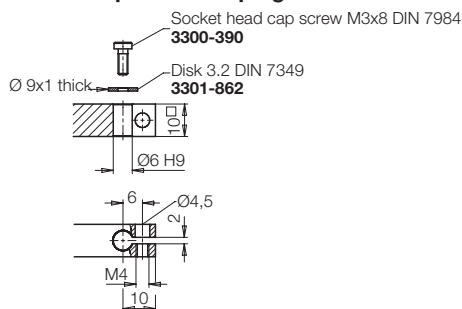

Accessory

Clamping strap 0354-230

for clamping with minimum deformation

