



Swing Clamps with Reinforced Swing Mechanism

bottom flange, position monitoring optional,
 double acting, max. operating pressure 500 bar

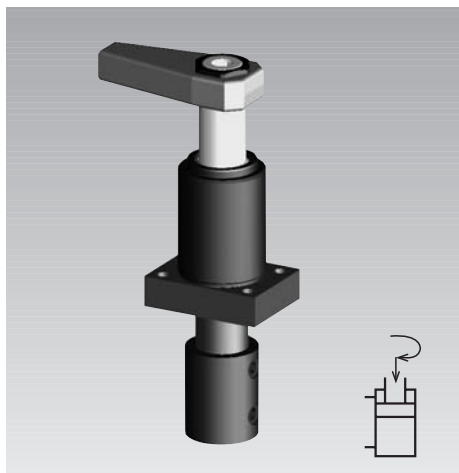

Figure with position monitoring

Application

Hydraulic swing clamps are used for clamping of workpieces when it is essential to keep the clamping area free of straps and clamping components for unrestricted workpiece loading and unloading. Due to the sturdy swing mechanism and the extended switch rod they are particularly suited for

- Clamping fixtures with workpiece loading via handling systems
- Transfer lines
- Test systems for motors, gears, axes, etc.
- Automatic manufacturing systems
- Assembly lines

Description

This line is a further development of the proved ROEMHELD swing clamps with the aim to improve process safety in linked clamping systems. The most important characteristics are as follows:

1. Omission of the overload protection device
 In the case of a slight collision with the clamping arm during loading and unloading of the fixture, the angular position of the clamping arm will be maintained. Less critical are the weight of the clamping arm or an increased swing speed.
2. Reinforced swing mechanism
 The reinforced swing mechanism endures a collision of the clamping arm with the workpiece during clamping up to a pressure of 100 bar.
3. FKM wiper
 This wiper has a high chemical resistance when using aggressive cutting fluids
4. Further types of bodies
 Flange at the top: data sheet B1.8801
 Threaded-body type: data sheet B1.8921

Connecting possibilities

Pipe thread

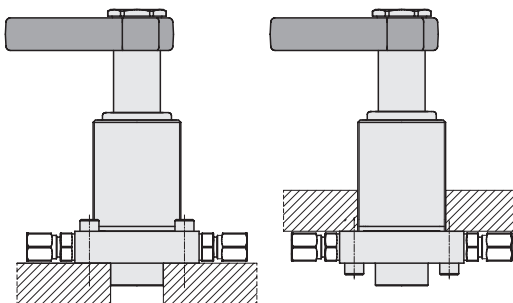

Drilled channels

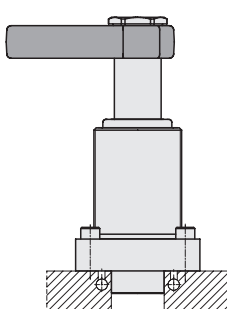

Versions

DH, DM: without switch rod

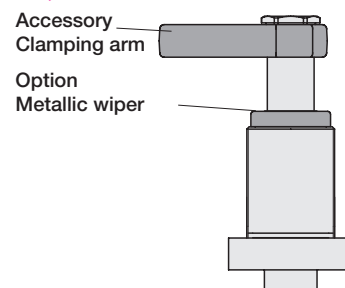

MH, MM: with switch rod

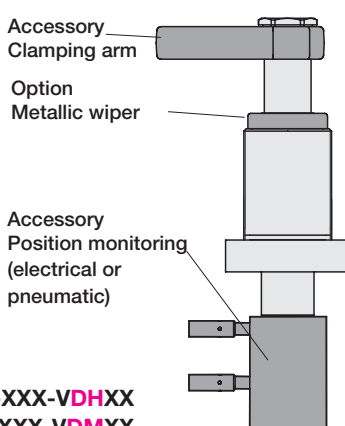

Part numbers

Without switch rod, without metallic wiper: **189X-XXX-VDHXX**

Without switch rod, with metallic wiper: **189X-XXX-VDMXX**

With switch rod, without metallic wiper: **189X-XXX-VMHXX**

With switch rod, with metallic wiper: **189X-XXX-VMMXX**

Options

Switch rod for position monitoring

The helix rod protrudes through the cover and allows thereby a pneumatic or electrical control of the piston position outside the swarf area. As an accessory a pneumatic position monitoring is available; the brass control slide being displaced in a stainless housing. The slide opens and closes bore holes, so that a pressure switch or a differential pressure switch can signal the position "Clamped" and "Unclamped". It is also possible to realise this monitoring directly in the fixture body by means of drilled channels. An electrical position monitoring with inductive proximity switches is also available (see page 2).

Metallic wiper

This wiper protects the FKM wiper against mechanical damage, e.g. by hot swarf. The swing clamp body is prepared for mounting of the metallic wiper. The wiper consists of a radially floating wiping disk and a retaining disk which will be pressed onto the existing collar.

Metallic wiper
 optional

Important notes

Due to the missing overload protection device, assembly and disassembly of the clamping arm has to be made carefully despite the reinforced swing mechanism. When tightening and untightening the fixing nut, the clamping arm or the hexagon socket in the piston has to be backed up. It is recommended to effect tightening and untightening in the swivel area. Frequent collisions with the clamping arm in radial direction have to be avoided.

For interpretation of the pneumatic pressure we recommend to use a differential switch.

Parallel connection for up to 8 swing clamps is possible. For a greater number there are special solutions. Please contact us.

Further important notes see data sheet B 1.881.

Dimensions

Technical characteristics • Accessories

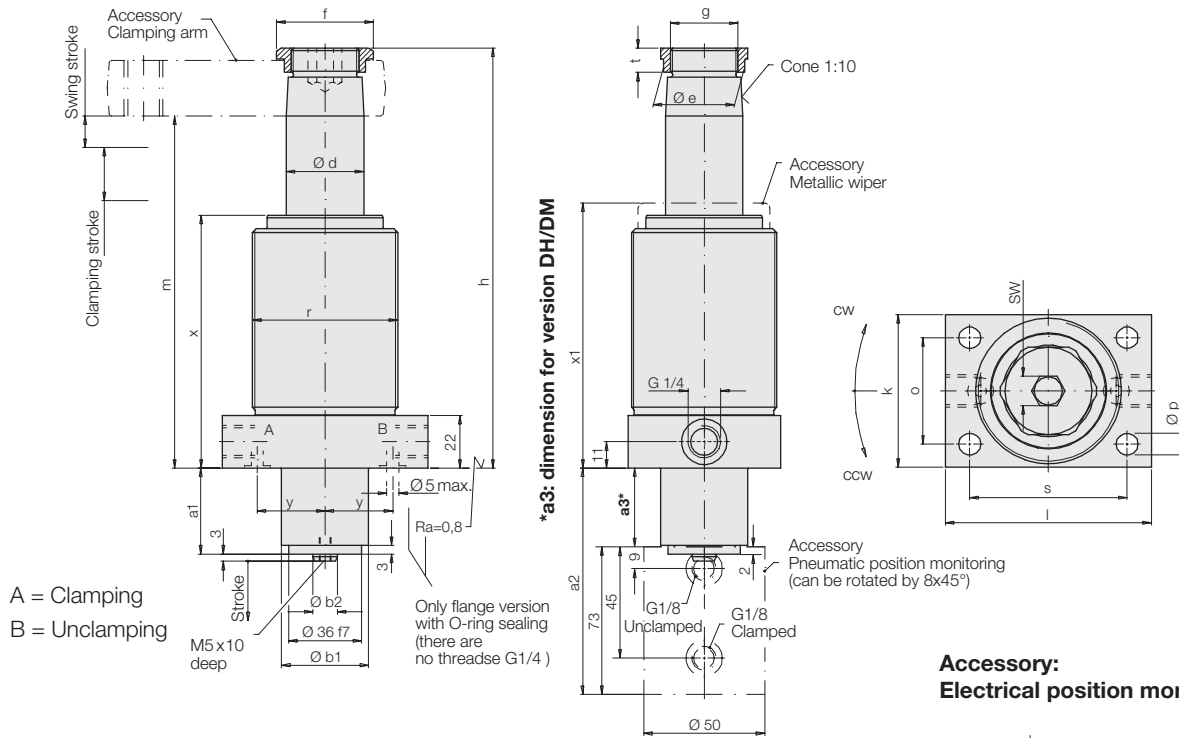

Clamping stroke	[mm]	22	20	20
Swing stroke	[mm]	13	16	18
Total stroke	[mm]	35	36	38
Operating pressure, min.	[bar]	30	30	30
Max. oil flow rate	[cm ³ /s]	20	36	55
Oil volume / stroke	[cm ³]	15.8	25.4	43.8
Oil volume / return stroke	[cm ³]	41.2	66.6	114.2
a1	[mm]	35.5	38	41
a2	[mm]	106.5	109	112
a3*	[mm]	25.5	25	16
Ø b1 -0.1	[mm]	36	45	45
Ø b2 f7	[mm]	10	12	12
Ø d	[mm]	32	40	50
Ø e	[mm]	33.5	45	55.5
f	[mm]	40	55	68
g	[mm]	M 28x1.5	M 35x1.5	M 45x1.5
h	[mm]	173.5	192	209
k	[mm]	63	80	90
l	[mm]	85	100	115
m -1	[mm]	145.5	158	169
o	[mm]	44	60	68
Ø p	[mm]	8.5	13.5	16
r	[mm]	M 60x1.5	M 80x2	M 90x2
s	[mm]	65	80	90
t	[mm]	10	11	12
x	[mm]	103.5	113	124
x1	[mm]	108.5	118	129
y	[mm]	28	31	37.5
SW	[mm]	12	17	17

Accessory: Electrical position monitoring

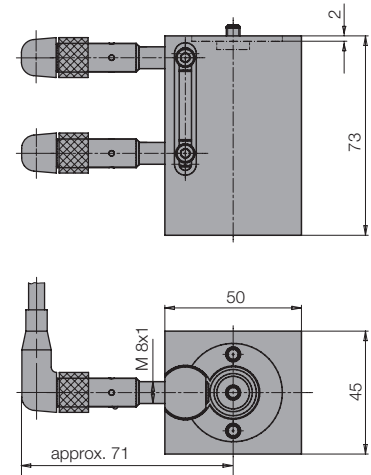

Function charts

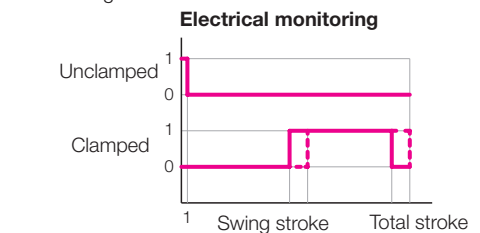
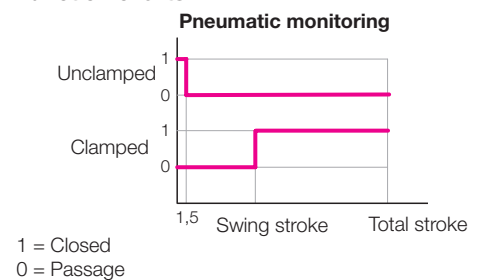

Part-no. flange type

Swing direction 90° cw	1895-108-VXX35	1896-108-VXX36	1897-108-VXX38
Swing direction 90° ccw	1895-208-VXX35	1896-208-VXX36	1897-208-VXX38
0 degree	1895-248-VXX35	1896-248-VXX36	1897-248-VXX38

Part-no. flange type for manifold mounting with O-ring sealing

Swing direction 90° cw	1895-508-VXX35	1896-508-VXX36	1897-508-VXX38
Swing direction 90° ccw	1895-608-VXX35	1896-608-VXX36	1897-608-VXX38
0 degree	1895-648-VXX35	1896-648-VXX36	1897-648-VXX38

XX: Version **DH/DM** = without/with metallic wiper without switch rod
MH/MM = without/with metallic wiper with switch rod

Accessories

Pneumatic position monitoring, complete	0353-808	0353-809	0353-810
Electrical position monitoring			
– without switch	0353-815	0353-813	0353-813
– with standard switch and angle plug	0353-814	0353-811	0353-811
Metallic wiper, complete (spare part)	0341-100	0341-101	0341-102

Clamping force diagrams and other accessories: see data sheet B 1.881. Further proximity switches: see data sheet B 1.552.

Code number for available swing angles

Swing angle (±1°)	Part-no.
90°	189X-X0X-VXXXX
60°	189X-X2X-VXXXX
45°	189X-X3X-VXXXX