



## Threaded-Body Work Supports

M 30 x 1.5, with metallic wiper edge, 4 sizes, double acting, max. operating pressure 500 bar



### Advantages

- High process safety by double-acting function
- 4 sizes
- Space-saving threaded-body version
- Contact force by spring
- Load force up to 6.5 or 9.5 kN
- Metallic wiper edge and FKM wiper
- Corrosion-resistant interior parts

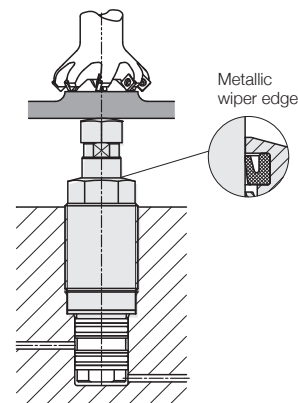

### Application

Hydraulic work supports are used to provide a self-adjusting rest for the workpiece during the machining operations. They compensate the workpiece surface irregularities, also vibration and deflection under machining loads.

The threaded-body design allows for space-saving and direct installation into the fixture body. Oil supply is made through drilled channels.

In case of the double-acting version the return stroke of the support plunger is effected in a precisely defined time, that is above all advantageous in cycle-dependent installations.

### Description

In the body of the threaded-body work support a thin-walled locking bush is integrated, which locks cylindrically around the freely-movable support plunger when pressurising the element with hydraulic oil.

The support plunger is extended and retracted by means of a small double-acting cylinder. The threaded-body work supports are protected against swarf by a metallic wiper and sealed against liquids.

### Important notes!

Work supports are not suitable to compensate side loads. The support plunger must not be stressed by tensile load.

The admissible load force is valid for static or dynamic load. Machining forces can generate vibrations, whose amplitude far exceeds an average value, and this can cause yielding of the support plunger. Remedy: increase the safety factor or the number of work supports. In case of accumulation of very small grinding swarf there can be a swarf holdup in the area of the metallic wiper edge. Remedy: regular cleaning in this area.

Work supports must only be operated with a sealed contact bolt.

For special versions of contact bolts, we can provide you with a drawing showing the interior contour.

Operating conditions, tolerances and other data see data sheet A 0.100.

### Function

The support plunger is retracted in off-position. When pressurised the piston of the double-acting cylinder extends and the support plunger contacts the already clamped workpiece with spring force.

The support plunger will be locked by the increasing hydraulic pressure and can compensate forces in axis direction.

For unclamping the pressure will be reduced and the return line will be supplied with pressure.

The piston returns to its off-position and retracts the support plunger.

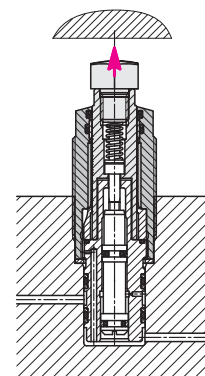

### Combination with clamping elements

Load and clamping forces have to be adapted to each other, so that there will be sufficient force reserve available for the threaded-body work support to absorb the machining forces.

Rough estimate:

**Min. load force  $\geq 2 \times$  clamping force**

The opposite diagram shows the course of the load and clamping force for the possible combination of 194X-11X with a threaded-body swing clamp 1891-XX1 as per data sheet B 1.891. The vertical distance of the two straight lines in the area of the colorised surface indicates the maximally possible machining force including reserve.

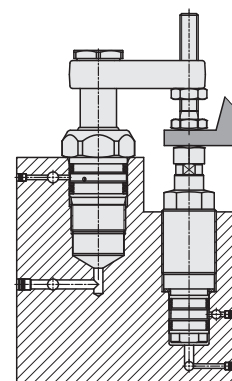

### Example

Threaded-body swing clamp 1891-101 and threaded-body work support 1942-112.

Operating pressure 200 bar

As per diagram:

Adm. load	3.0 kN
- Clamping force	1.5 kN
Possible machining force	1.5 kN

If this force is not sufficient the work support can also be supplied with 500 bar. The pressure for the swing clamp will be reduced.

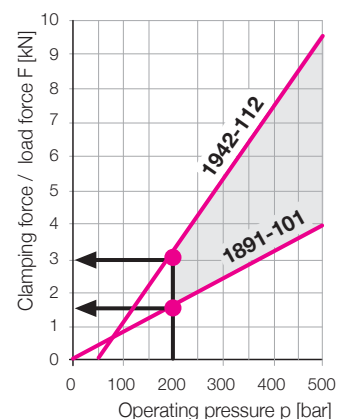

# Dimensions Technical Characteristics

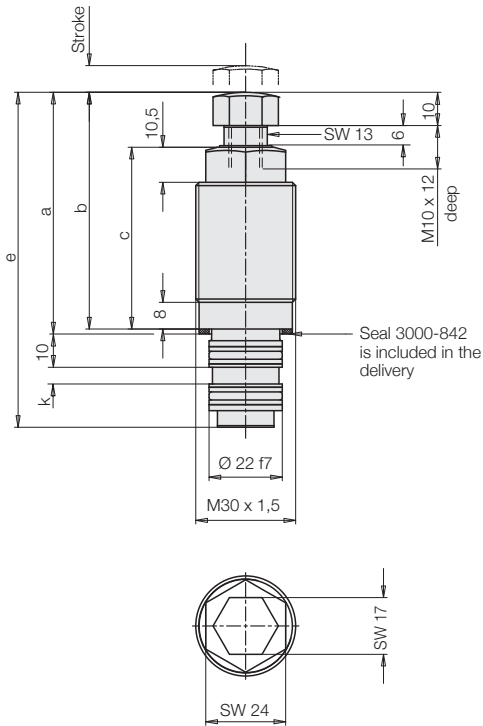

## Porting details

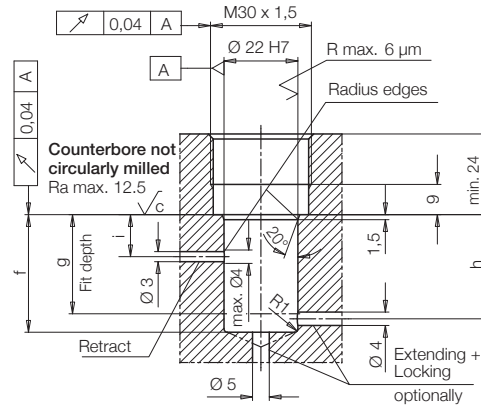

### Technical characteristics

Adm. load force [500bar]	[kN]	6.5	6.5	9.5	9.5
Stroke	[mm]	8	15	8	15
Support plunger Ø	[mm]	16	16	16	16
Oil volume extend	[cm <sup>3</sup> ]	0.7	1.2	0.7	1.2
retract	[cm <sup>3</sup> ]	0.2	0.3	0.2	0.3
Admissible flow rate	[cm <sup>3</sup> /s]	25	25	25	25
Recommended min. pressure	[bar]	100	100	100	100
Minimum pressure to retract	[bar]	20	20	20	20
Spring force min./max.	[N]	16/33	10/22	16/33	10/22
Elastic deformation with load and 500 bar	[µm/kN]	4	4	4	4
Max. operating temperature	[°C]	80	80	80	80
Tightening torque	[Nm]	60	60	60	60
a	[mm]	72.5	79.5	82.5	89.5
b	[mm]	71	78	81	88
c	[mm]	54.5	61.5	64.5	71.5
e	[mm]	100.5	113	110.5	123
f	[mm]	29.5	35	29.5	35
g	[mm]	24	29.5	24	29.5
h	[mm]	26.5	32	26.5	32
i	[mm]	13	14.5	13	14.5
k	[mm]	5	8	5	8
Weight approx.	[kg]	0.32	0.36	0.36	0.40
<b>Part-No.</b>		<b>1942-102</b>	<b>1942-107</b>	<b>1942-112</b>	<b>1942-117</b>

### Admissible load force F as a function of the operating pressure p

