



Threaded-Body Work Support
M 40 x 1.5, with metallic wiper edge,
single acting, max. operating pressure 500 bar



Advantages

- Space-saving threaded-body version
- 3 types of operation
- Contact force by spring or pneumatically adjustable (1941 201)
- Load force up to 15 kN
- Metallic wiper edge and FKM wiper
- Venting of the spring area
- Connection of positive air pressure protection is possible
- Mounting body as accessory

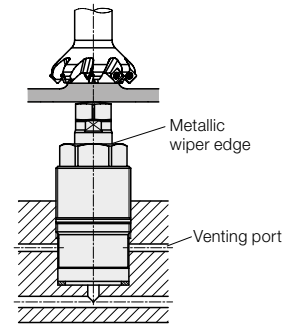

Installation and connecting possibilities

Drilled channels with accessory and mounting body

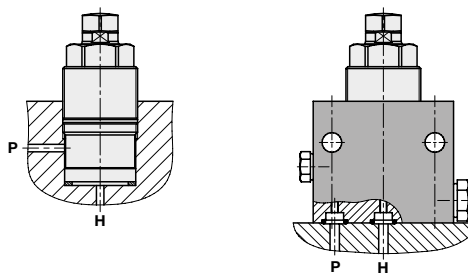

Pipe thread

with accessory mounting body

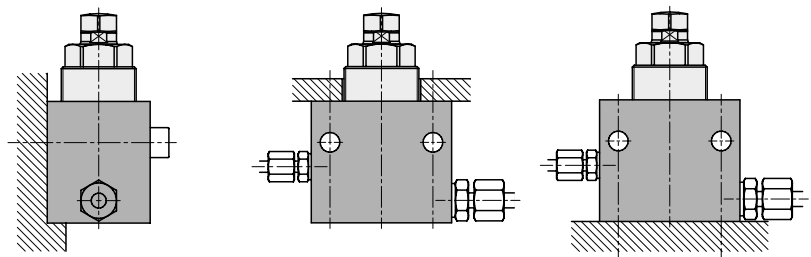

Combination with clamping elements

Support and clamping forces have to be adapted to each other, so that there will be sufficient force reserve available for the threaded-body work support to absorb the machining forces.

Rough estimate:

Support force $\geq 2 \times$ clamping force

Example

Threaded-body swing clamp 1883 102 and threaded-body work support 1942 201. Operating pressure 200 bar (because of the clamping arm)
As per diagram:

Adm. load force	5.0 kN
- Clamping force	2.3 kN
Possible machining force	2.7 kN

To get a higher support force, the threaded-body work support can be supplied with 500 bar and the pressure for the swing clamp can be reduced.

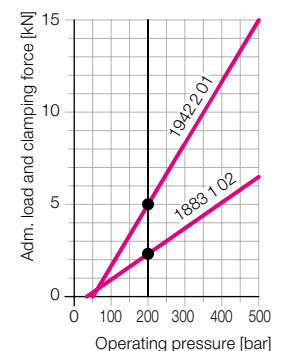
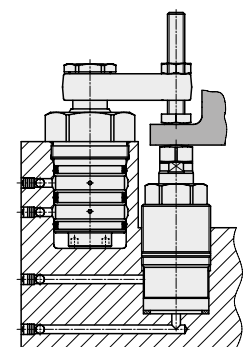

Application

Hydraulic work supports are used to provide a self-adjusting rest for the workpiece during the machining operations. They compensate the workpiece surface irregularities, also vibration and deflection under machining loads. The threaded-body design allows for space-saving and direct installation into the fixture body. Oil supply is made through drilled channels.

Description

In the body of the threaded-body work support a thin-walled locking bush is integrated, which locks cylindrically around the freely-movable support plunger when pressurising the element with hydraulic oil.

For contact of the support plunger at the workpiece there are 3 possibilities (description see page 2):

1. Spring force
2. Air pressure advanced
3. Oil pressure combined with spring force

The elements are protected against penetration of swarf by a metallic wiper edge and sealed against liquids.

The venting port allows also the connection of air sealing.

A mounting body for pipe threads or drilled channels is available as accessory.

Important notes!

To guarantee functioning of the work supports, a vent port is imperative.

No liquids may enter into the bore hole (see also page G 0.110 "Venting of the spring area").

Activate positive air pressure protection < 0.2 bar only after hydraulic locking and deactivate before unclamping.

Special contact bolts M 12 must have a thread length of 12 mm. Work supports are not suitable to compensate side loads.

The admissible load force as per diagram on page 2 is static. Machining forces can generate vibrations, whose amplitude exceeds far an average value, and this can cause yielding of the support plunger.

Remedy: increase the safety factor or the number of work supports.

Technical data Accessories • Dimensions

Part no. 1940201

Part no. 1941201

Part no. 1942201

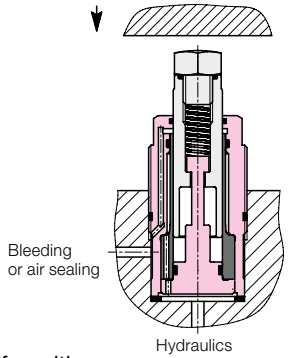

Off-position:
Plunger extended
Contact with spring force

The support plunger is pushed back by the inserted workpiece, the spring force has to be overcome.

The support plunger will be locked by hydraulic pressure and can compensate forces in axis direction.

After unclamping the support plunger contacts still the workpiece with spring force, until the workpiece will be unloaded from the fixture.

Technical data

Support plunger Ø	[mm]	20
Stroke	[mm]	10
Adm. load force at 500 bar	[kN]	15
Recommended minimum pressure	[bar]	100
Spring force min./max.	[N]	20/32
Plunger contact force at 1 bar air pressure (deduct spring force!)	[N]	31
Max. air pressure for positive air pressure protection	[bar]	0,2
Required oil per stroke (1942201)	[cm ³]	1
Admissible oil flow rate (1942201)	[cm ³ /s]	25
Seating torque	[Nm]	100
Weight approx.	[kg]	0,6

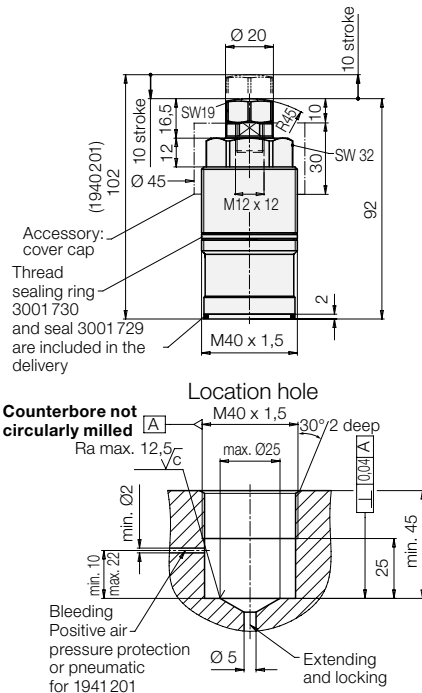

Before mounting!
Location hole oil free and dry.

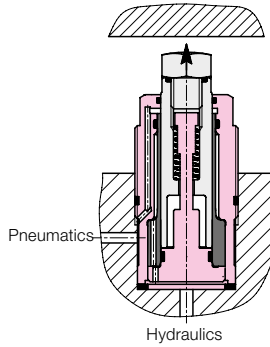

Off-position:
Plunger retracted
Extend and contact with air pressure

The support plunger contacts the workpiece by air pressure. The contact force is proportional to the air pressure less spring return force.

The support plunger will be locked by hydraulic pressure and can compensate forces in axis direction.

For unclamping hydraulic and air pressure will be released and the support plunger retracts by spring force to its off-position.

Accessories

Mounting body	0346801
O-ring 10x2	3000347
Spare sealing ring 38/30x2	3001729
Spare thread sealing ring	3001730
Screw plug G1/4	3610264
Screw plug G1/8	3610263
Cover cap	35371009

Mounting body

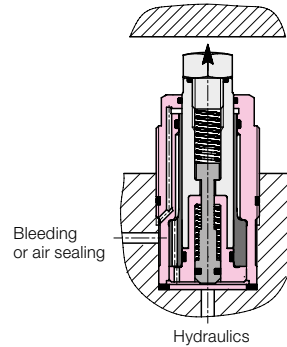
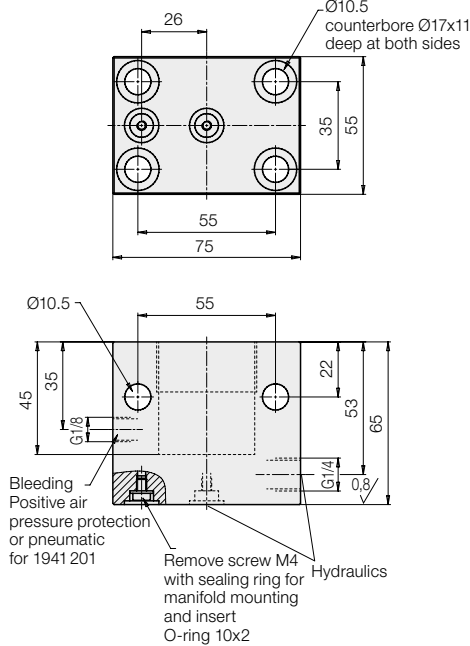

Off-position:
Plunger retracted
Extend with hydraulics
Contact with spring force

The support plunger is extended by a hydraulically pressurised small piston and contacts the workpiece with spring force.

The support plunger will be locked by the increasing hydraulic pressure and can compensate forces in axis direction.

For unclamping hydraulic pressure will be released. The small piston retracts by spring force to its off-position and also retracts the support plunger.

Sharp-edged orifice 0.6 mm for 1942201

If the flow rate is larger than 25 cm³/s (1.5 l/min), malfunctions may occur.

By the installation of the sharp-edged orifice and a special sealing ring the extending speed of the support plunger is reduced.

Part no. 0341 108

Please note:

The standard sealing ring 38/30x2 cannot longer be used. The sealing ring 3002035 delivered with the sharp-edged orifice is 1 mm thicker, so that the measure of length increases from 92 to 93 mm.

The sharp-edge orifice has to be inserted in the location hole so that letter A is pointing upwards.

Admissible load force F as a function of the operating pressure p.

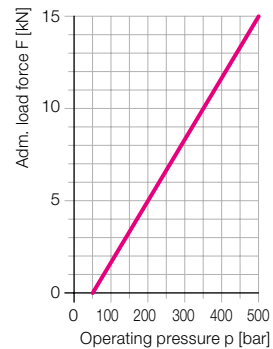

Variation in length of the support plunger during load.

