

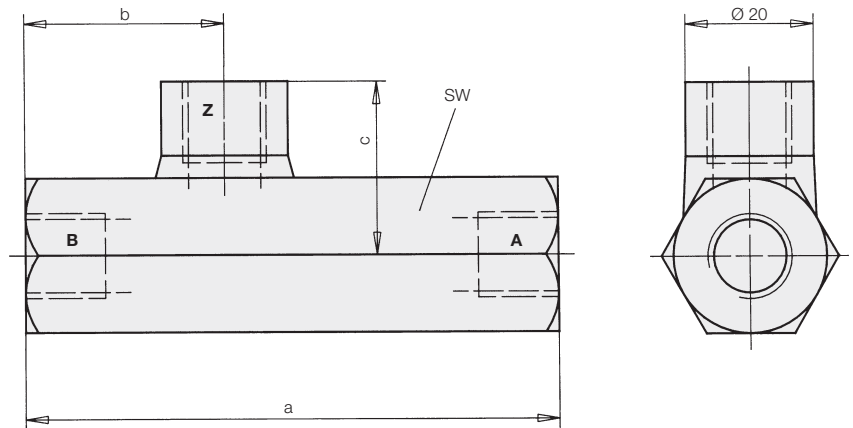

**Pilot-Operated Check Valve**  
without/with pre-release, version with pipe thread,  
max. operating pressure 500 bar

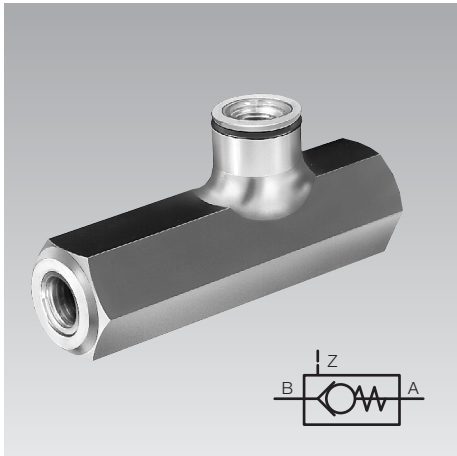

**General information**

Pilot-operated check valves are spring-loaded poppet valves with free flow from B to A and blocked flow in the opposite direction that can be "unblocked" by pressurizing the control port Z.

The minimum pressure required for unblocking depends on the height of the counter pressure at port A (see diagram).

In the version with pre-release first a smaller poppet valve located in the main valve piston is opened. This offers the following advantages:

1. The control pressure required for opening is considerably lower, and thereby the use of swing clamps with unfavourable surface ratios is possible.
2. Pressure reduction is effected relatively softly. That saves all hydraulics components and the noise level sinks.

**Technical data and dimensions**

Max. flow rate	[l/min]	15	55
Max. operating pressure	[bar]	500	500
Control flow	[cm <sup>3</sup> ]	0.15	0.4
Control pressure pz (p <sub>B</sub> =0 bar)			
without pre-release *)	[bar]	0.32xp <sub>A</sub> +12	0.38xp <sub>A</sub> +12
with pre-release	[bar]		0.087xp <sub>A</sub> +12
a	[mm]	84	100
b	[mm]	31.5	36.5
c	[mm]	27	31
SW	[mm]	24	32
Ports A,B		G1/4	G1/2
Control port Z		G1/4	G1/4
Weight	[kg]	0,4	0,6
<b>Part-no.</b>			
without pre-release *)		<b>2951-417</b>	<b>2951-501</b>
with pre-release			<b>2951-421</b>

**Application example**

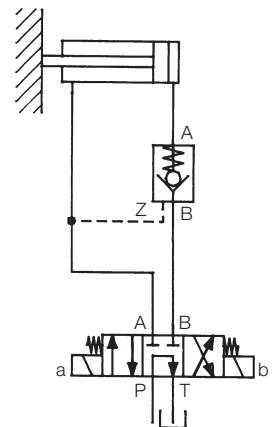

**Application**

Blocking of leakage-free cylinders combined with non leakage-free directional control valves and pressure maintenance on uncoupled parts of the installation (clamping pallets).

**Important notes!**

In the case of swing clamps and pull-type cylinders, a dangerous pressure intensification can occur during unclamping, if the release pressure is not sufficient for opening. Therefore check valves with pre-release must be used, that require a substantially lower opening pressure.

**Minimum pressure pz for unblocking**  
at pressure p<sub>A</sub> (p<sub>B</sub> = 0 bar)

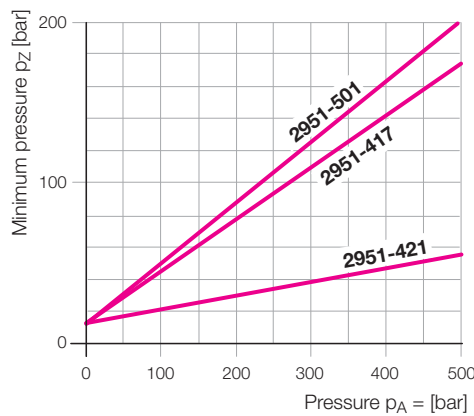

**Δ p-Q characteristic curves**  
valid for flow direction B → A  
and unblocked direction A → B  
for kinematic viscosity of 60 mm<sup>2</sup>/s

