

Pilot-Operated Check Valve

without/with pre-release, manifold-mounting type,
max. operating pressure 500 bar

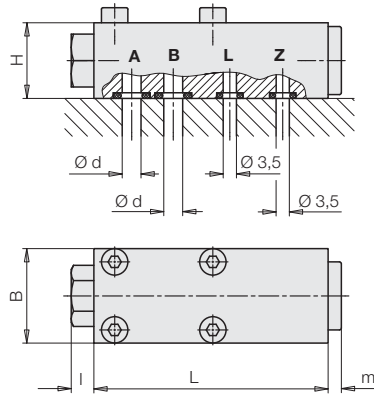

Drilling pattern of the base plate

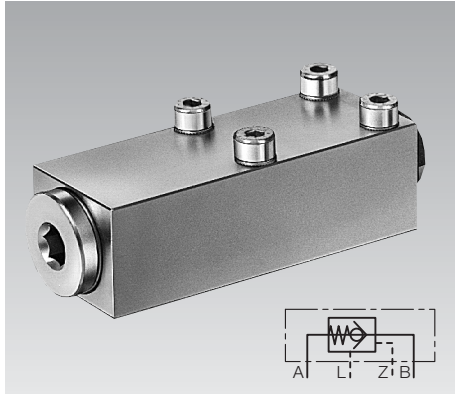
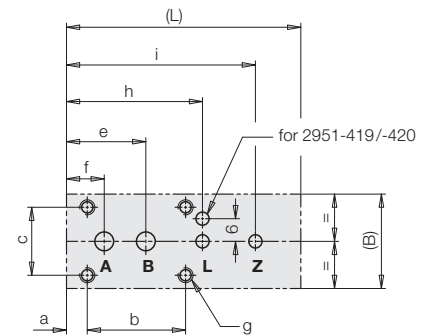

General information

Pilot-operated check valves are spring-loaded poppet valves with free flow from B to A and blocked flow in the opposite direction that can be "unblocked" by pressurising the control port Z.

The minimum pressure required for unblocking depends on the height of the counter pressure at port A (see diagram).

In the version with pre-release first a smaller poppet valve located in the main valve piston is opened. This offers the following advantages:

1. The control pressure required for opening is considerably lower, and thereby the use of swing clamps with unfavourable surface ratios is possible.
2. Pressure reduction is effected relatively softly. That saves all hydraulics components and the noise level sinks.

Application

Blocking of leakage-free cylinders combined with non leakage-free directional control valves and pressure maintenance on uncoupled parts of the installation (clamping pallets).

Using the manifold-mounting type, connections without pipes can be realised on the fixture body (see application example).

Important notes!

In the case of swing clamps and pull-type cylinders, a dangerous pressure intensification can occur during unclamping, if the release pressure is not sufficient for opening. Therefore check valves with pre-release must be used, that require a substantially lower opening pressure.

The leakage port for the relief of the piston area is imperative for a safe functioning. It has to be protected against liquids and contamination.

Technical characteristics

Max. flow rate	[l/min]	20	50
Max. operating pressure			
A,B,Z	[bar]	500	500
L	without pressure to oil reservoir		
Control flow	[cm ³]	0.2	0.5
Control pressure p _Z (p _B = 0 bar)			
without pre-release *)	[bar]	0.318xp _A +4	0.222xp _A +4
with pre-release	[bar]		0.053xp _A +4
4 fixing screws		M4x25	M6x45
Seating torque	[N/m]	2.6	9
L	[mm]	62	70
B	[mm]	25	35
H	[mm]	20	35
a	[mm]	5.5	9
b	[mm]	26	26
c	[mm]	18	25
Ød	[mm]	5	9
e	[mm]	21	31
f	[mm]	10	13
g	[mm]	M4x5 deep	M6x10 deep
h	[mm]	36	42
i	[mm]	50	56
l	[mm]	9	9
m	[mm]	3.5	4
Weight	[kg]	0.3	0.7

Part-no.

without pre-release *)	2951-416	2951-419
with pre-release		2951-420
O-rings **)		
Port A,B 6.07x1.78	3000-942	
A,B 9.19x2.62		3000-022
Port L,Z 4.47x1.78	3000-968	3000-968
Fixing screws **)		
M4x25	3300-580	
M6x40		3300-229

*) Pay attention to important notes!

**) Are included in our delivery.

Application example

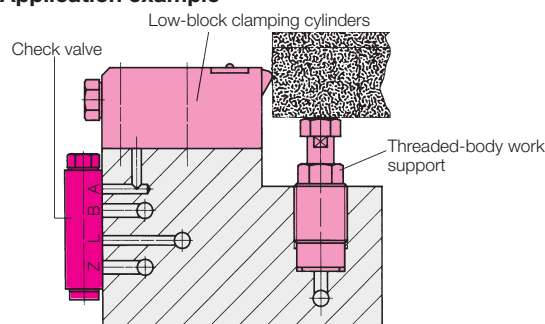

Minimum pressure p_Z for unblocking at pressure p_A (p_B = 0 bar)

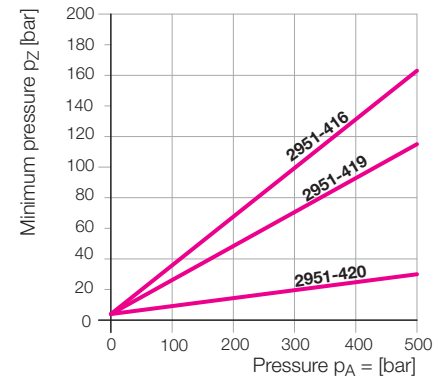

Δ p-Q characteristic curves for kinematic viscosity of 60 mm²/s

