

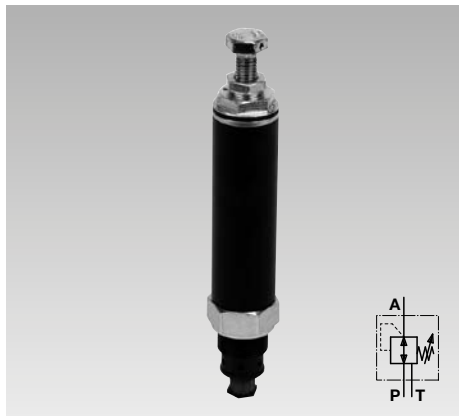

Pressure Reducing Valves
Poppet valve with overpressure function
max. operating pressure 500 bar



Advantages

- Optimisation of the clamping force of individual cylinders or subassemblies
- Pressure limitation to the admissible operating pressure of individual cylinders or subassemblies.
- Automatic readjustment in case of pressure drop
- Overpressure function prevents pressure increase at the consumer
- Additional safety valves are not required
- Large adjustment range
- Possibility to lead
- Different connecting possibilities

Low pressure



High pressure

Definition

Pressure reducing valves keep the outlet pressure constant, also in case of a changeable, but always higher inlet pressure.

Application

In hydraulic clamping systems, it is often necessary to pressurise single clamping elements or groups of clamping elements with reduced pressure.

This version with overpressure function compensates not only a pressure drop, but also a pressure increase above the preset pressure. For this purpose, a separate line to the reservoir must be provided. Possible causes for a pressure increase are:

- Temperature increase (approx. 10 bar per 1°C)
- Force increase acts on the clamping cylinder
- Damage of the valve seat by swarf

Limits of application

This pressure reducing valve can only be used in static clamping systems. The connected clamping elements must be leakage-free.

Important notes!

The reservoir port P must not be closed to guarantee a perfect functioning. For clamping systems that will be uncoupled from the pressure generator, this valve can only be used under certain conditions.

Examples for the connection to the reservoir line see page 3 "Hydraulic circuit diagrams".

The outlet pressure can be set and controlled by means of a pressure gauge. Thus, also the required sealing of the system is monitored.

In the case of incorrect pressure setting, there may be a risk of injury due to overload of the connected elements.

For the installation of further valves, pay attention to the application example.

Function

Below the set outlet pressure, the hydraulic oil flows unhindered from P to A. In case of a pressure increase, the set spring force is overcome and a check valve cuts off the flow hermetically sealed. Thus, a further pressure increase is avoided, also in case of increasing inlet pressure p. In case of a pressure drop, e.g. because of a leakage at a cylinder, the check valve will be opened by a strong spring against the existing inlet pressure p. Hydraulic oil can continue flowing until the set outlet pressure is obtained.

If the outlet pressure increases, e.g. because of oil warming, a pressure relief valve opens. Thus, oil in the outlet pressure area can drain off by the reservoir line until the preset outlet pressure is more or less obtained and the pressure relief valve is closed.

A return flow from A to P is only possible if the inlet pressure p drops below the set outlet pressure.

Connecting possibilities

Screw-in valve

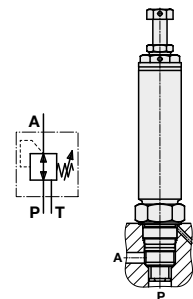

Pipe thread

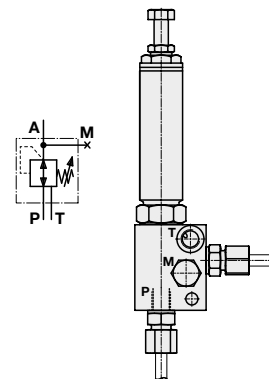

Manifold-mounting connection

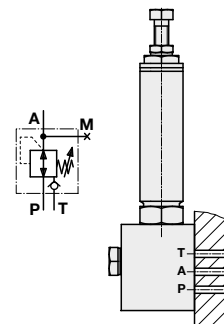

Maximum flow rate

The maximum volume flow rate depends on the selected adjustment range of the outlet pressure (see table on page 2).

If the flow rate of the pump is higher, a flow control valve has to be installed in front of the pressure reducing valve.

Application example

To guarantee perfect functioning of the pressure reducing valves, flow control valves and sequence valves must always be installed in front of the pressure reducing valve in the shown sequence.

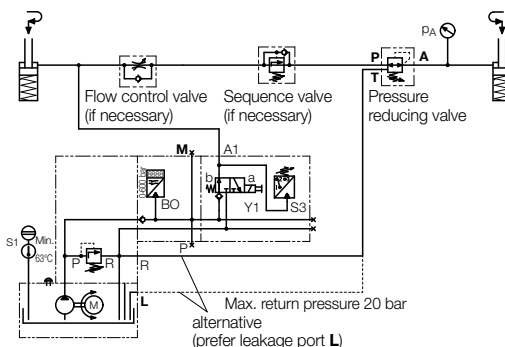

Pressure reducing valves without overpressure function see data sheet C 2.9533.

Technical data Dimensions

Type	Adjustment range [bar]	Max. flow rate [l/min]	Part no. Screw-in valve	Part no. Pipe thread	Part no. Manifold-mounting connection
①	(10)* 30...380	10	2953200	2953211	2953215
②	8...130	4...10**	2953201	2953213	2953216
* see diagram "Minimum set pressure"					
** see diagram "Max. flow rate"					
				Connecting block without pressure reducing valve	
				0353441	03531006

Technical data

Type	3-way ball-type poppet valve
Mounting position	any
Max. operating pressure p_p (inlet pressure)	500 bar
Adjustment range (outlet pressure)	see part no.
Max. flow rate	see part no.
Max. return pressure p_T	20 bar
Δp -Q characteristic curve	see diagram
Hydraulic oil	HLP as per DIN 51524
Viscosity class	ISO VG 10...68 as per DIN 51519
Viscosity range	10...500 mm ² /s (recommendation)
Purity class	20 / 17 / 13 as per ISO 4406
Oil temperature	-25...+80 °C
Environmental temperature	-40...+80 °C

Δp -Q characteristic curves (P → A and A → P)

(with open valve, if p_p is smaller than p_A)
Test medium viscosity: 50 mm²/s (cSt)

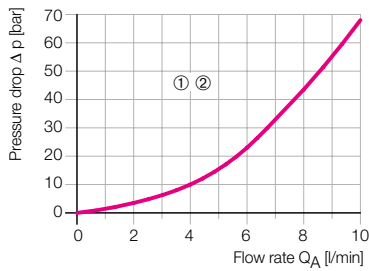

Minimum set pressure p_A min.

as a function of the inlet pressure p_p

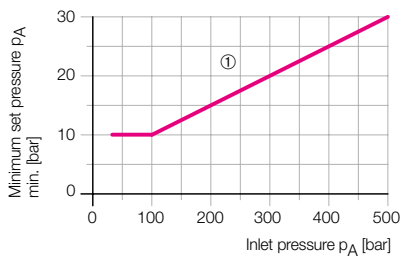

Max. flow rate

as a function of the set outlet pressure p_A

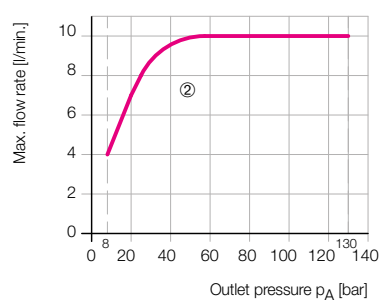

Screw-in valve ①+② Weight: approx. 0.7 kg

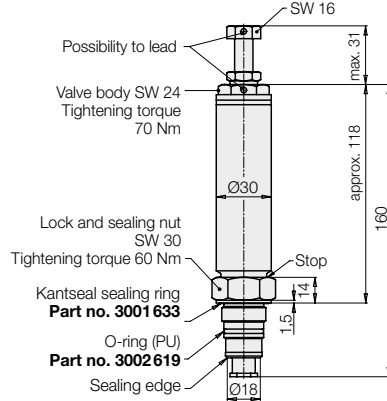

Location hole

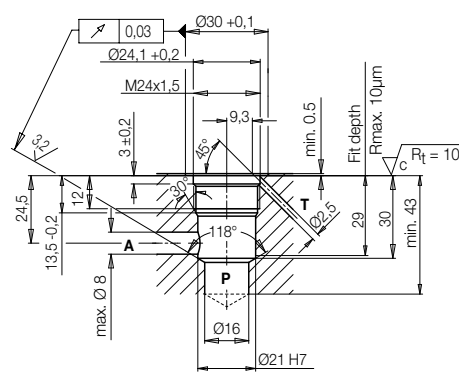

Installation note

- Before screwing in, turn back lock and sealing nut up to the stop.
- Screw in valve body and tighten by 70 Nm. Sealing is made metallically on the counterbore of 118°.
- Tighten the lock and sealing nut by 60 Nm. Sealing is made by the Kantseal sealing ring on the counterbore diameter of 30 mm. The sealing ring is included in the delivery.

Disassembly is made in reverse sequence.

Possible increase or drop of the outlet pressure Δp_A before starting of the control function

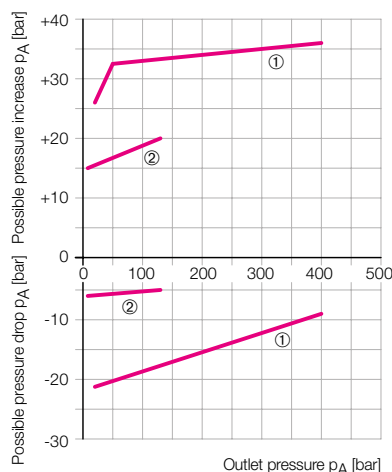

Pipe thread ①+② Weight: approx. 1.3 kg

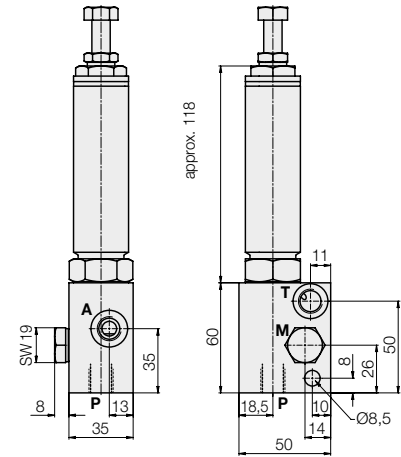

Ports **P, A, M, T** = G 1/4

- P** = input
- A** = output
- M** = pressure gauge connection
- T** = reservoir connection

Manifold-mounting connection ①+② Weight: approx. 1.3 kg

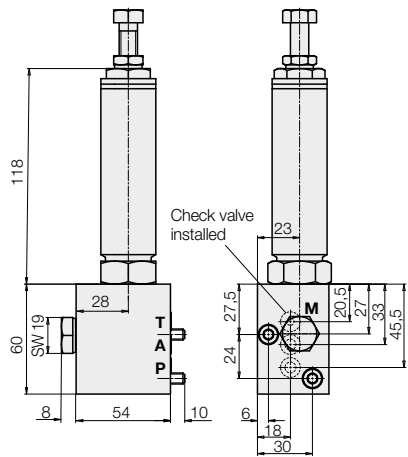

Connecting scheme

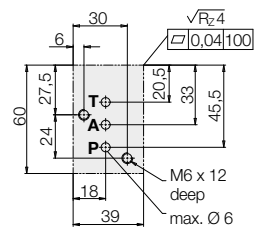

Included in our delivery:

2 O-rings 8x1.5
Part no. 3000343

1 O-ring 6x1.5
3000313

2 screws M6 x 40 DIN 912-12.9

Part no. 3301200

Tightening torque 18 Nm

1. Single-acting cylinders

1.1. Clamping fixtures

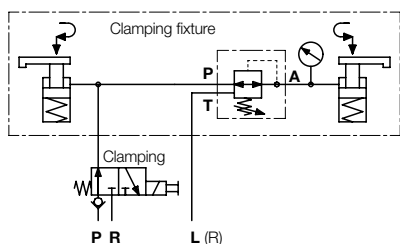

When using a pressure reducing valve with reservoir connection, always a 2nd line is required to connect port T with port L or R at the power unit.

1.2 Clamping pallet without coupling unit

If only one line with one coupling is available, the pressure reducing valve with overpressure function cannot be used.

Alternative:

A pressure reducing valve without overpressure function in combination with an additional safety valve (see data sheet C 2.9533).

1.3 Clamping pallets with coupling unit as per data sheet F 9.425 for double-acting cylinders

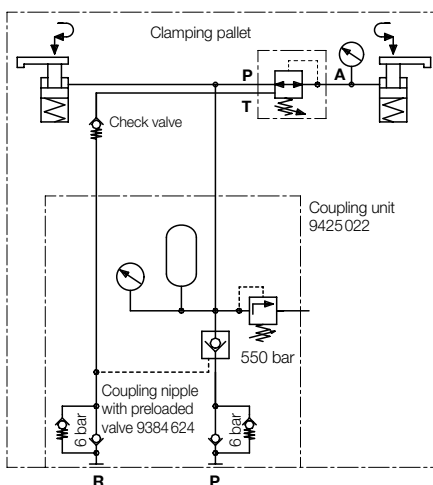

Despite of the fact that this coupling unit has two ports, it is also possible to use it with single-acting cylinders. The second port is only required to open the pilot-controlled check valve and for the reservoir line of the pressure reducing valve.

The coupling unit is equipped with two special coupling nipples with integrated preloaded valve (VSV). They avoid a possible pressure increase in the unclamping line by opening at an overpressure of 6 bar and draining a small quantity of oil. If a pressure reducing valve is required on the clamping pallet, this feature can be used to connect the reservoir line with the unclamping line. An additional check valve avoids a pressure increase at the port T of the pressure reducing valve during unclamping.

Alternative:

The additional non-return valve is not required if the pressure reducing valve with manifold-mounting connection can be used. A check valve is installed as standard in the connecting block (see hydraulic symbol on page 1).

2. Double-acting cylinders

2.1. Clamping fixtures

2.1.1 Separate reservoir line

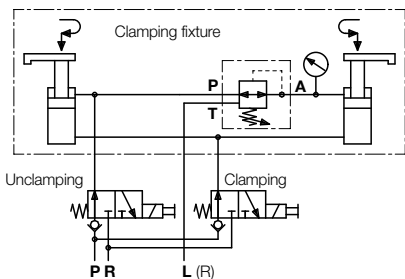

The easiest way is to install a third line from port T of the pressure reducing valve to port L or R of the power unit.

2.1.2 Use of the unclamping line

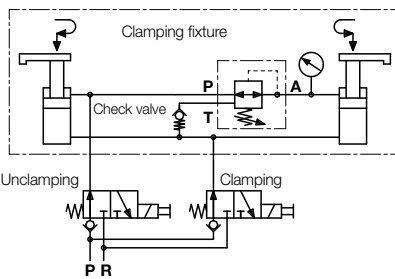

Port T can be connected with the unclamping line, when that line is without pressure during the clamping process.

An additional check valve avoids a pressure increase at the port T of the pressure reducing valve during unclamping.

Alternative:

The additional non-return valve is not required if the pressure reducing valve with manifold-mounting connection can be used. A check valve is installed as standard in the connecting block (see hydraulic symbol on page 1).

2.2 Clamping pallet with pressure-tight coupling nipple in the unclamping line

The use of a pressure reducing valve with overpressure function is not possible (see important notes on page 1).

Alternative:

A pressure reducing valve without overpressure function in combination with an additional safety valve (see data sheet C 2.933).

2.3 Clamping pallets with coupling unit as per data sheet F 9.425

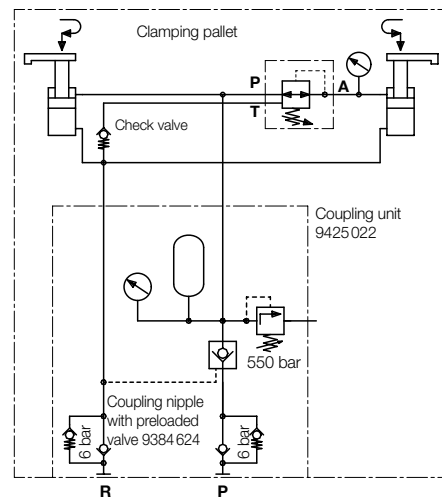

The coupling unit is equipped with two special coupling nipples with integrated preloaded valve (VSV). They avoid a possible pressure increase in the unclamping line by opening at an overpressure of 6 bar and draining a small quantity of oil.

If a pressure reducing valve is required on the clamping pallet, this feature can be used to connect the reservoir line with the unclamping line. An additional check valve avoids a pressure increase at the port T of the pressure reducing valve during unclamping.

Alternative:

The additional non-return valve is not required if the pressure reducing valve with manifold-mounting connection can be used. A check valve is installed as standard in the connecting block (see hydraulic symbol on page 1).