

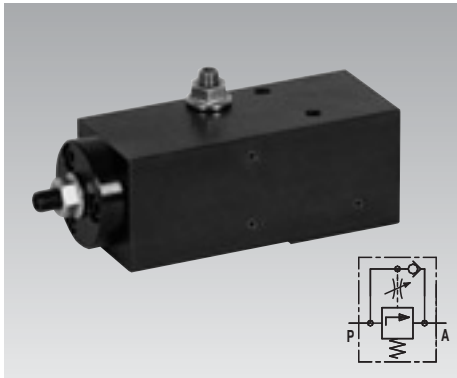

Sequence Valve ND 5

with time-dependent switching sequence,
max. operating pressure 250 bar



Advantages

- Realisation of switching sequences not dependent on pressure
- Cost reduction due to less control valves and pipes
- Big adjusting range
- Oil supply through drilled channels
- Subplate for pipe thread available
- Similar connecting scheme as sequence valves as per data sheet C 2.954

Application

This valve is especially suitable for clamping fixtures with pressure-independent sequence controls or for switching sequences that have to run with a determined adjusted delay.

Description

The adjustable switching delay allows a time-dependent switching sequence of hydraulic elements within a hydraulic circuit, independent of the hydraulic pressure.

On principle the valve has to be preadjusted to the hydraulic conditions with reference to pressure, viscosity and temperature (see: adjusting instructions, step 2).

Parallel or series connection of several valves is possible. The compact design facilitates the installation directly at the clamping fixture.

Function

A control piston is mounted in the valve body, that opens a check valve after an adjustable delay time.

As long as pressure is applied to P, this check valve is first closed.

The hydraulic oil flows through the flow control valve "rough adjustment" to the control piston, whose return stroke is limited by means of the adjusting screw "precise adjustment" (see dimensional drawing on page 2).

Adjusting possibilities:

Rough adjustment → Piston speed

Precise adjustment → Piston stroke

When the control piston opens the check valve, the hydraulic oil has free passage and the connected cylinders extend. After pressure relief at port P the hydraulic oil returns through the check valve from A to P and the connected cylinders retract. Also the control piston returns by the spring force to its off-position.

Technical characteristics

Type	Hydro-mechanically operated poppet valve	
Type of mounting	Flange joint with screws 2 x M5	
Oil supply	Drilled channels with O-ring sealing Subplate for pipe thread (see accessories)	
Max. operating pressure	[bar]	250
Min. operating pressure	[bar]	30
Adm. flow rate	[l/min]	8
Adjusting range of time delay	[s]	approx. 1-10
Weight	[kg]	1.5
Part-no.	2954-836	

Important notes

Reproducibility of the time delay

The reproducibility of the adjusted switching sequence depends on constant hydraulic conditions.

A highly variable oil temperature can change the adjusted delay time. It is therefore necessary to ensure that valve adjustment is always made at operating temperature.

Pressure increase

During the time delay the system pressure can increase to the maximum operating pressure depending on the rough adjustment of the throttle.

That is the reason why the pressure switches can give the signal "Clamped" even though the clamping process has not yet been completed.

Pressure drop

The opposite application example shows a typical application.

As described, when opening this sequence valve the pressure at cylinder 1 will drop completely. Only after cylinder 2 has moved against the stop, the pressure will be built up again. Possible remedies show 3 examples on page 2.

Application example

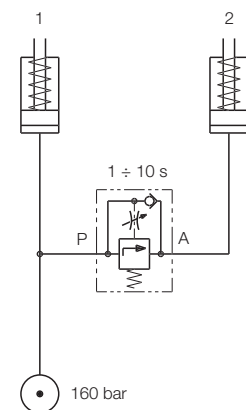

Clamping sequence:

1. Cylinder 1 moves without pressure against the stop.
2. Oil pressure increases up to 160 bar.
3. After the adjusted switching time the sequence valve opens and cylinder 2 moves without pressure against the stop. In the process cylinder 1 becomes again nearly pressureless. (Remedy - see page 2)
4. The oil pressure at both cylinders increases up to 160 bar.

Dimensions

Adjusting instructions • Circuit examples

Dimensions

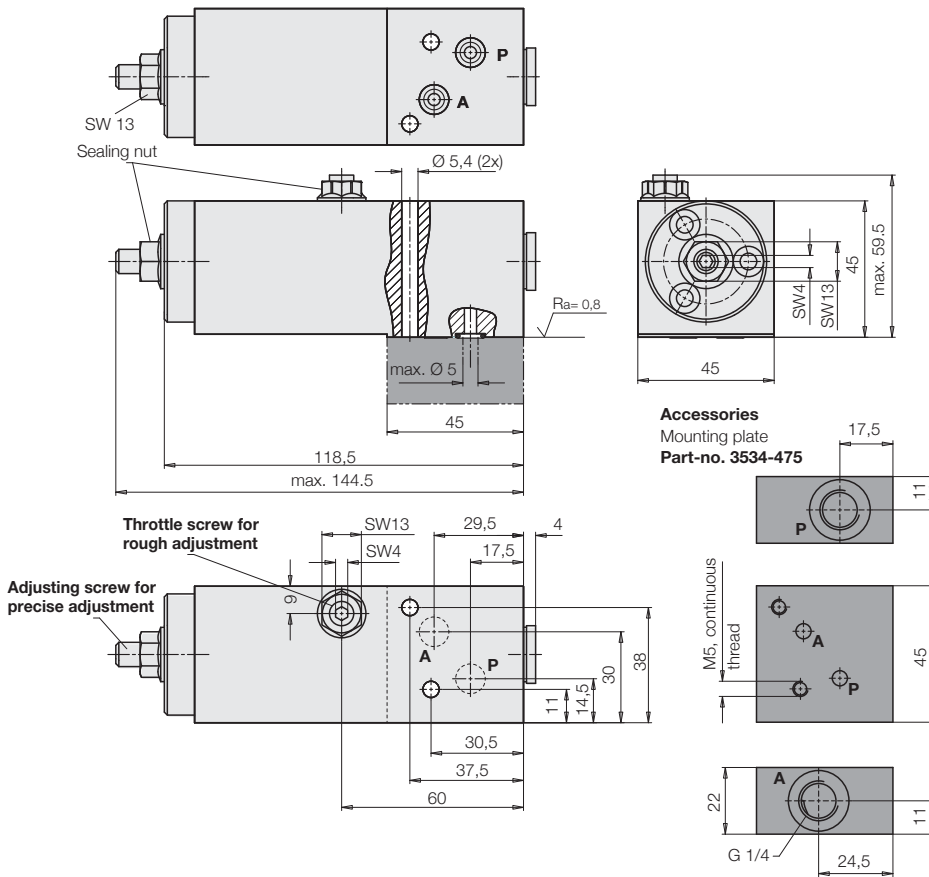

Adjusting instructions

During start up the hydraulic system has to be well bled.

The valve is preset at the factory to approx. 7 seconds at a flow rate of 2 l/min and a pressure of 150 bar. If the adjusted time has to be changed, it is usually sufficient to use the adjusting screw "precise adjustment" (see 4).

Otherwise a basic setting has to be made.

Basic setting

All settings must be made in **depressurised mode only**, otherwise hydraulic oil will escape. When loosening or tightening the sealing nut, hold the set screw (hexagon socket) to avoid changes of the setting.

1. Loosen the sealing nut "precise adjustment" and unscrew the set screw up to the stop. Tighten sealing nut.
2. Operate the hydraulic system several times and measure the delay time. Nominal value 7-10 seconds.
3. If the preset time is longer, loosen the sealing nut "rough adjustment" and slightly unscrew the adjustment screw. Tighten the sealing nut and repeat measurement until the nominal value is obtained.
4. Adjust shorter times by the "precise adjustment":
Loosen the sealing nut "precise adjustment" and screw in the set screw (several turns).
Attention! If the set screw is screwed in beyond a sensible stop, the locking function of the check valve will be cancelled and the valve will switch immediately. Retighten the sealing nut and measure the time.

Examples to avoid a pressure drop

1. Series connection with standard sequence valve (data sheet C 2.954)

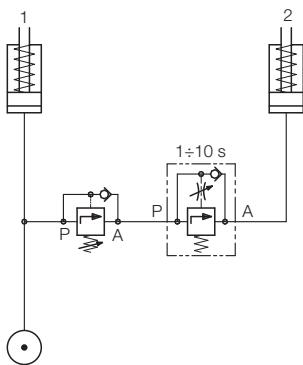

Adjustment

Since this sequence valve works pressure-dependent, it has to be adjusted to the opening pressure which should not be fallen below at cylinder 1 during the pressureless extension of cylinder 2.

Advantage

Combination of pressure-dependent sequence switching with adjustable time delay.

Disadvantage

Additional expense

2. Pilot-operated check valve (data sheets C 2.9511 and C 2.9512)

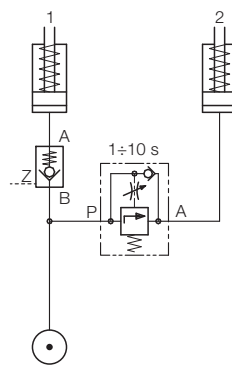

Adjustment

Not required.
The pressure obtained at cylinder 1 remains constant

Advantage

Maximum safety against pressure drop.

Disadvantage

The hydraulic control must have a double-acting function to open the check valve.

3. Series connection with flow control valve (data sheet C 2.940)

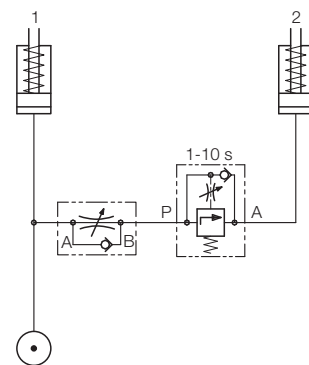

Adjustment

The flow control valve has to be shut off at system operational temperature so that during extension of cylinder 2 the pump pressure (pressure gauge) does not drop below the desired value.

Advantage

Minimum additional expense

Disadvantage

Adjustment depends on viscosity.
No safety for minimum pressure level at cylinder 1.
Extension of cylinder 2 will be throttled.