

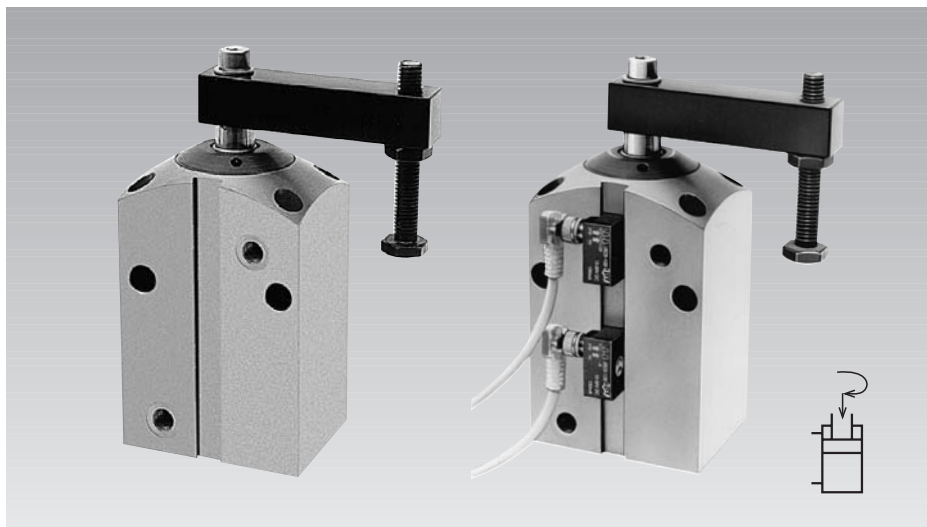

Pneumatic Swing Clamp

block-type, for adjustable magnetic sensors
 double acting, max. operating pressure 7 bar



Advantages

- Compact design
- Easy adjustment of switching point positions
- Diverse mounting possibilities
- 5 standard sizes are available
- optionally with thread connection or for manifold mounting with O-ring sealing

Application

Pneumatic swing clamps are used for applications which require only low clamping forces. The installed magnetic piston allows monitoring of clamping and unclamping position.

Description

When pressurising the element, the clamping arm swings and lowers by 90° to the clamping position and then lowers to the clamping point. The position monitoring gives the required information regarding the position of the piston, but not regarding the position of the clamping arm. Monitoring is made by electronic sensors (see accessory) which detect the magnetic field of the magnetic piston. The switching points can be continuously adjusted by displacement of the magnetic sensors.

Special features

When adjusting the clamping screw it has to be considered that for the swing motion a part of the total stroke is required. Make sure that the swing motion can be effected without any interference. When using special clamping arms with other lengths, the corresponding operating pressures as shown in the clamping force diagram must not be exceeded.

Pneumatic accessories

see data sheet J 7.400.

Installation

The block-type offers universal mounting possibilities.

Material

The swing clamps are supplied in corrosion resistant quality. Guide bushing, housing, piston, and flange are made of hardcoated aluminium. The piston rod is made of corrosion resistant steel.

Important notes

Operating of these pneumatic elements has to be effected with an additional service unit in order to guarantee that the clamping elements are supplied with correctly prepared compressed air.

Operating conditions, tolerances and other data see data sheet A 0.100.

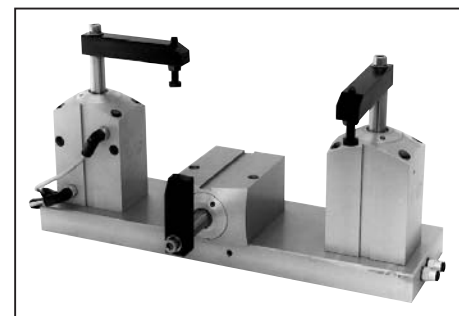

Versions

- Versions with pipe thread (Figure at the left-hand side) see page 2
- Manifold mounting with O-ring sealing Version **K** (Figure in the centre), see page 3
- Manifold mounting with O-ring sealing Version **B** (Figure at the right-hand side), see page 3

Connection example

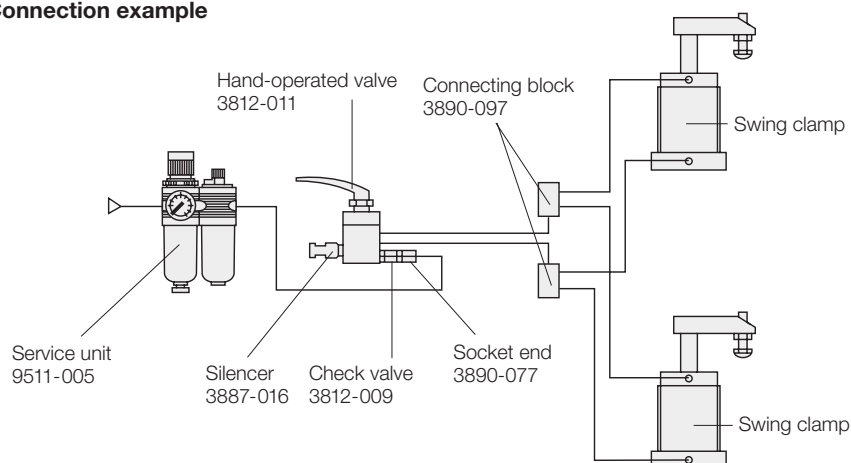

Threaded body

Technical characteristics • Accessories

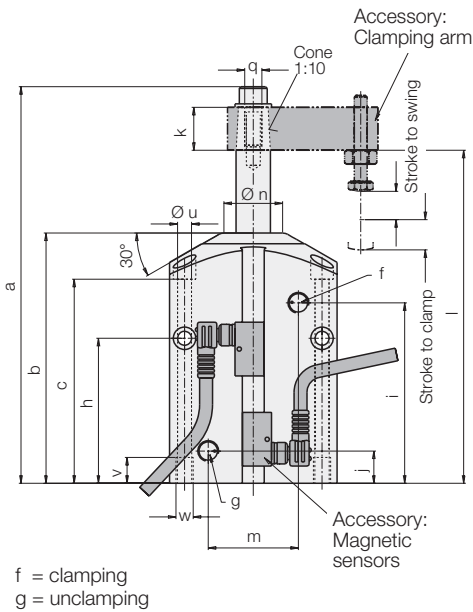

Piston Ø	[mm]	20	32	40	50	63
Piston rod Ø	[mm]	8	12	16	20	25
Stroke to swing	[mm]	7.5	9.5	17	18	23
Stroke to clamp	[mm]	7	9	15	15	18
Pulling force at 4 bar	[N]	105.5	276.4	422.2	659.7	1050.5
* air 5 bar	[N]	131.9	345.5	527.7	824.6	1313.1
pressure 6 bar	[N]	158.3	414.6	633.3	989.6	1575.8
Min. operating pressure	[bar]	3				
Max. operating pressure	[bar]	7				
Angle of rotation	[°]	90° ± 2°				
Weight	[kg]	0.35	0.8	1.3	2.0	3.33
a	[mm]	120.5	143	189.5	203.5	239.5
b	[mm]	76	94.5	120.5	130	150
c	[mm]	55.5	72	99	104	118
f	[mm]	M5	M5	G 1/8	G 1/8	G 1/4
g	[mm]	M5	M5	G 1/8	G 1/8	G 1/4
h	[mm]	41	59.5	71.5	76	80
i	[mm]	53.5	63	88	95	100
j	[mm]	17	20	19	17.5	18
□ k	[mm]	12	16	20	25	30
l	[mm]	103.5	119.5	159	164	197
m	[mm]	22	28	42	44	58
Ø n	[mm]	14	24	30	38	42
o	[mm]	54	68	80	90	106
p	[mm]	35	52	60	70	85
q	[mm]	M4	M6	M8	M12	M10
r	[mm]	40	55	64	72	86
s	[mm]	22	38	42	48	66
t	[mm]	25	40	46	50	70
u	[mm]	5.5	6.5	6.5	8.5	8.5
Ø u	[mm]	10	12	12	15	15
w	[mm]	M8	M8	M8	M10	M10
Clockwise rotation	Part-no.	1873-106	1874-106	1875-106	1876-106	1877-106
Counterclockwise rotation	Part-no.	1873-206	1874-206	1875-206	1876-206	1877-206

* Effective clamping force see diagram (page 3, column 1)

Seat of clamping arm

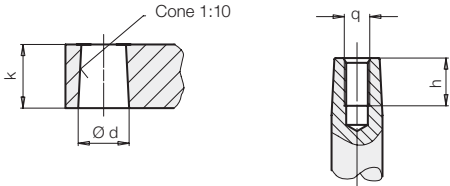

Swing clamp	Ø d + 0.05	□ k	h	q
1873-X06	7.85	12	9	M 4
1874-X06	11.85	16	15	M 6
1875-X06	15.85	20	19	M 8
1876-X06	19.85	25	18	M 12
1877-X06	24.85	30	25	M 10

Clamping arm

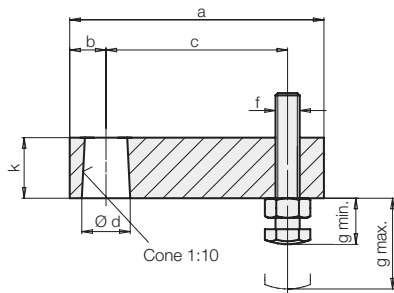

Swing clamp	a	b	c	Ø d + 0.05	f	g min.	g max.	□ k	Part-no.
1873-X06	54	7	42	7.85	M 4	8	28	12	0187-326
1874-X06	68	10	52	11.85	M 6	12	27	16	0187-426
1875-X06	78	12	58	15.85	M 6	12	42	20	0187-526
1876-X06	90	14	68	19.85	M 8	15	42	25	0187-626
1877-X06	110	18	80	24.85	M10	19	56	30	0187-726

Clamping arms for special versions

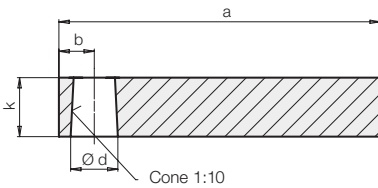

Swing clamp	a	b	Ø d + 0.05	□ k	Part-no.
1873-X06	62	7	7.85	12	3548-355
1874-X06	72	10	11.85	16	3548-356
1875-X06	95	12	15.85	20	3548-357
1876-X06	116	14	19.85	25	3548-353
1877-X06	143	18	24.85	30	3548-358

Contact bolt, dome head

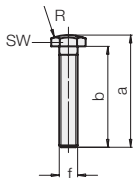

Swing clamp	a	b	f	R	SW	Part-no.
1873-X06	32.5	30	M 4	15	7	3614-141
1874-X06	33.5	30	M 6	20	10	3614-137
1875-X06	48.5	45	M 6	20	10	3614-138
1876-X06	50	45	M 8	20	13	3614-139
1877-X06	66.5	60	M 10	35	17	3614-140

Manifold mounting with O-ring sealing

Technical characteristics

Effective clamping force

1873-X06 Max. clamping arm length c [mm]

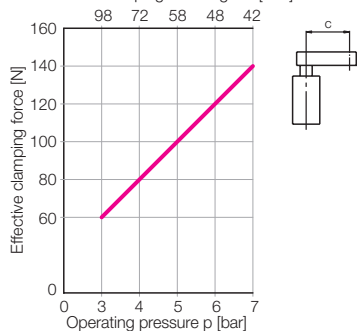

1874-X06 Max. clamping arm length c [mm]

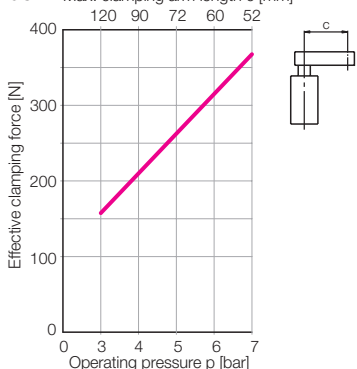

1875-X06 Max. clamping arm length c [mm]

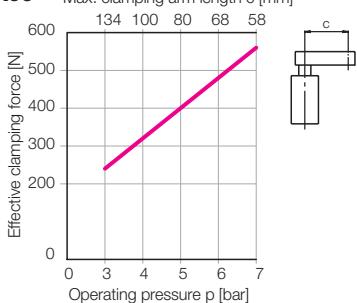

1876-X06 Max. clamping arm length c [mm]

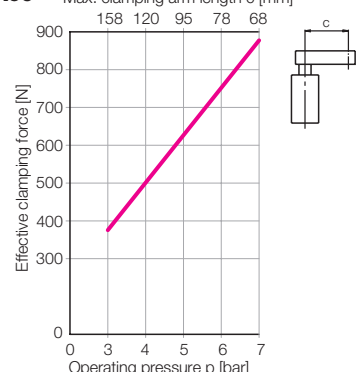

1877-X06 Max. clamping arm length c [mm]

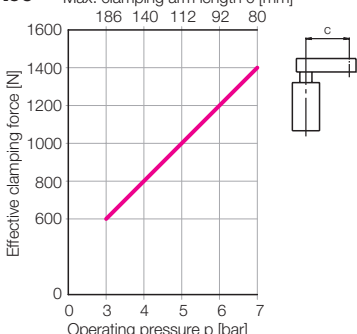

Version K
(Broad side)

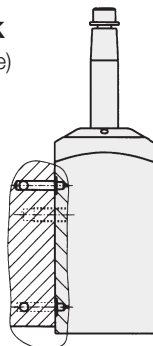

Version B
(Bottom side)

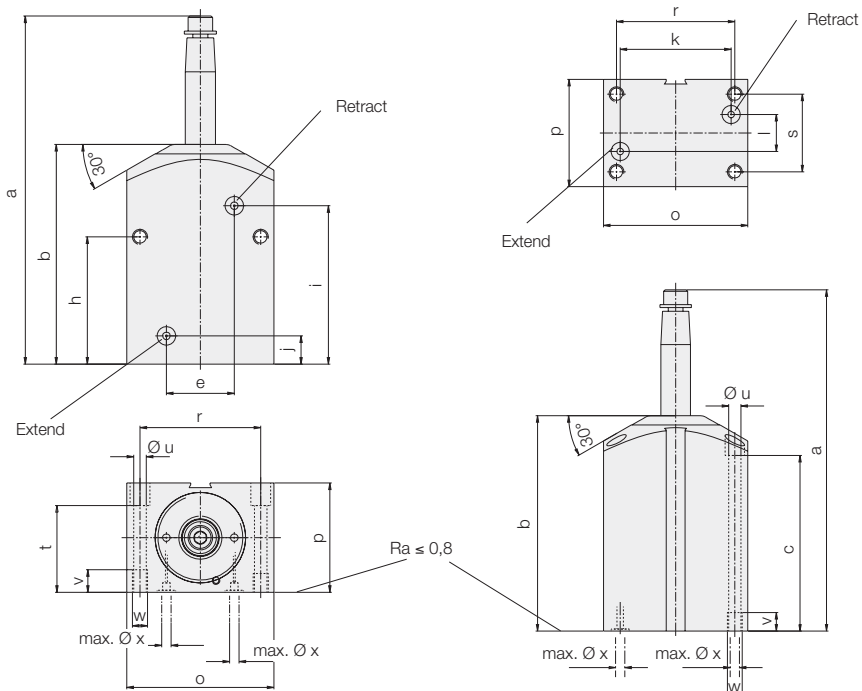
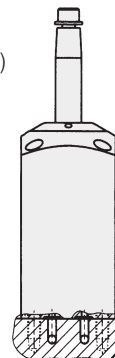

Swing clamp

	1873-106X	1874-106X	1875-106X	1876-106X	1877-106X
Clockwise rotation	1873-206X	1874-206X	1875-206X	1876-206X	1877-206X
Counterclockwise rotation					
Piston Ø	[mm] 20	32	40	50	63
Piston rod Ø	[mm] 8	12	16	20	25
a	[mm] 120.5	143	189.5	203.5	239
b	[mm] 76	94.5	120.5	130	150
c	[mm] 55.5	72	99	104	118
e	[mm] 16	28	36	44	58
h	[mm] 41	59.5	71.5	76	80
i	[mm] 53.5	63	88	95	100
j	[mm] 20	20	19	17.5	18
k	[mm] 39	53	60	72	86
l	[mm] -	14	20	20	20
o	[mm] 54	68	80	90	106
p	[mm] 35	52	60	70	85
r	[mm] 40	55	64	72	86
s	[mm] 22	38	42	48	66
t	[mm] 25	40	46	50	70
Ø u	[mm] 5.5	6.5	6.5	8.5	8.5
v	[mm] 10	12	12	15	15
w	[mm] M8	M8	M8	M10	M10
max. Ø x	[mm] 5	5	5	5	5
Dimensions O-ring	[mm] 7x1.5	7x1.5	7x1.5	7x1.5	7x1.5

Part-no., spare O-ring **3000-342 3000-342 3000-342 3000-342 3000-342**

O-rings are included in delivery. Other dimensions see page 2.

Order:

Please add the corresponding identification letter to the **part-no.** of the required pneumatic block-type swing clamp: **K** or **B**

Example of ordering:

Pneumatic block-type swing clamp 1875-106 with air supply on the broad side
Part-no. 1875-106 K

Accessory: Magnetic sensors

Compared with traditional reed switches the electronic magnetic sensors offer the following advantages:

- Indifference to shock and vibration
- Bounce-free output signal
- Only one switching point
- Wear resistant
- Protection against reverse battery
- Protected against short circuits

Electric connection is made as per traditional inductive proximity switches; up to four magnetic sensors can be connected in series. Minimum distance of the switching points: 6 mm.

Important notes

Steel can influence the magnetic field of the magnetic piston and thereby the position of the switching points. If there is the same influence for each stroke (e.g. because of adjoining steel components) it can be compensated by displacing the magnetic sensors. But if the influence differs from stroke to stroke, as e.g. in the case of swarf, a cover has to be provided 30 mm over the magnetic sensors. Covers have to be provided to protect the cylinders against ferritic swarf.

Further information about voltage supply for position controls see data sheet A 0.120.

Electronic magnetic sensor

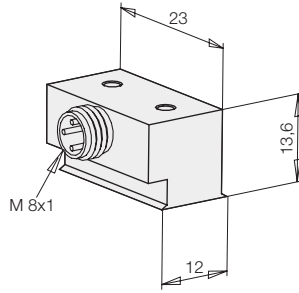

Temperature curve

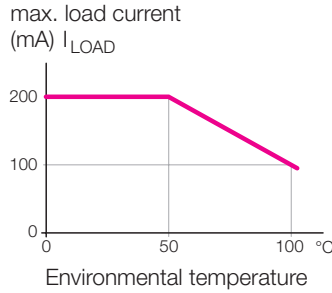

Connecting cable with right angle plug

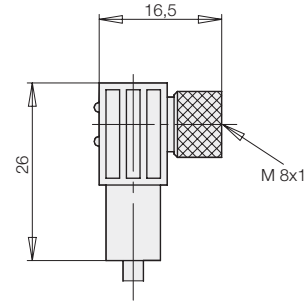

Connecting scheme

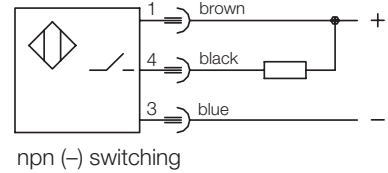
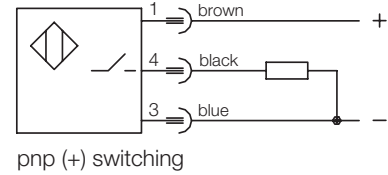

Technical characteristics

	Electronic magnetic sensor		Connection cable with right angle plug	
Cylinder body material	aluminium black lacquered			
Voltage	10 – 30 V DC		10 – 30 V DC	
Residual ripple	max. 10%			
Current load I _{LOAD}	200 mA – up to 50 °C 150 mA – at 75 °C 100 mA – at 100 °C			
Current consumption	< 15 mA			
Voltage drop (max. load)	< 2 V			
Protected against short circuits	yes			
Protection against reverse battery	installed			
Switching frequency	1 kHz			
Switching hysteresis	3 mm			
Protection as per DIN 40050	IP 67		IP 67	
Environmental temperature	–25 °C up to +100 °C		–25 °C up to +90 °C	
Plug connection	M8 plug		M8 plug	
LED	no		Voltage (green) Function display (yellow)	
Cable, length of cable			PUR, 5 m	
Output (interlock)	pnp	npn	pnp	npn
Part-no.	3829-234	3829-240	3829-099	3829-124

Further accessory

see data sheet G 2.140

- Pin-and-socket connector
- Y-distributor
- Reversing plug
- Voltage regulator

Range of magnetic signal

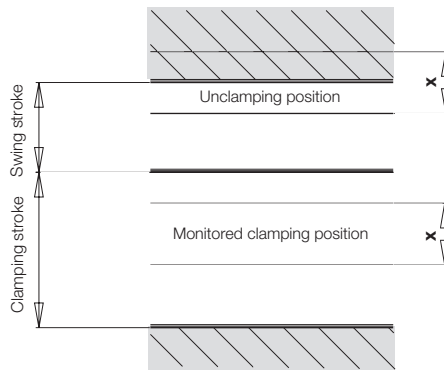

Type	≈ x [mm]
1873-X06	4
1874-X06	4
1875-X06	5
1876-X06	6
1877-X06	7