



Lifting Modules Strong

Max. lifting force 6,000 N, stroke from 200 to 400 mm,
 manual-hydraulic and electro-mechanical version



Advantages

- Lifting force up to 6,000 N
- High load by steel guiding profile with high section modulus
- Rigid guiding system without clearance
- Sturdy and tough
- Compact design
- Ergonomic design
- Safe and precise handling

Application

Lifting modules for high demands in the industrial assembly.

Principal use

- Industrial production plants
- Automotive industry
- Assembly of car seats
- Drive technology, axes, cardan shafts
- Compressors, hydraulic elements, pumps
- Turbines, motors, gearbox construction
- Applications with frequent load changes

Fixing and installation

For fixing of *modulog* modules or other components of the user at the top plate, the lifting module has an interface 140 x 140.

For fixing of *modulog* modules at the bottom plate, the lifting module has an interface 200 x 200. This plate can also be used to fix the lifting module on a flat level floor. For fixing, 4 screws M10 of property class 10.9 as well as heavy-duty plugs are to be used.

For increased stability also a base plate, which can be delivered as accessory, can be fixed at the bottom plate.

Description

The lifting module Strong has a high-tensile cylinder tube profile with chromium-plated surfaces. The high precision of the tube profile enables a guiding system without clearance and perfect smooth running.

The guiding profile is protected against rotary motion by a key connection with minimum clearance.

The guiding system works without fat and oil lubrication. High-quality materials for plain bearings are used.

Characteristic are applications with indifferent, dynamically swelling rotating motions and shock motions.

Material

Guiding system, top and base plates are made of steel. Materials for plain bearings are made on the base of polymers.

modulog

Lifting module

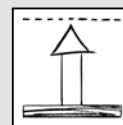

Part no. 8919-06-X0-X

Technical data

Max. lifting force:	6,000 N
Max. bending moment:	800 Nm
Stroke:	200 to 400 mm

Operations

- Foot pedal
- Foot switch
- Hand panel



Combinable with the modules

- Rotating modules – horizontal axis
 DMH 200 as per data sheet M 1.101,
 DMHe 200 as per data sheet M 1.201



- Tilting modules
 KMB 100 as per data sheet M 2.101
 KME 100 as per data sheet M 2.201



- Rotating modules – vertical axis
 DMV 600 as per data sheet M 1.301,
 DMVe 600 as per data sheet M 1.201



- Cart modules
 WMS as per data sheet M 5.101



- Floor modules
 FMS as per data sheet M 6.101



modulog interfaces

- Top plate: 140 x 140 - Ø 10.5 mm
- Bottom plate: 200 x 200 - Ø 10.5 mm

Accessories

- Electronic control modules for 1, 2, 3 or 4 lifting modules as per data sheet M 8.200
- Control modules with battery holder as per data sheet M 8.201
- Electrical operating elements, lines and connectors as per data sheet M 8.203
- Base and adaptor plates as per data sheet M 8.100 and M 8.110
- Table plates as per data sheet M 8.130 and M 8.131

Manual-hydraulic version operation with foot pedal



Description

The stroke movement is obtained by a hydraulic lifting jack with single-lever actuation, with oil being pumped by means of a piston pump into a plunger cylinder.

During retraction, the oil returns due to the weight of the load from the cylinder back to the reservoir. A defined speed reduction is effected.

The manual-hydraulic version is particularly sturdy and durable. This variant meets high safety demands and withstands jerking and knocking loads in applications.

Operation

To lift the load, the foot pedal has to be depressed by approx. 40° several times. The pedal returns to its off-position by means of a return spring.

To lower the load, the foot pedal has to be moved upwards by approx. 10°.

Per 100 mm stroke 10 pump motions are required.

Descent speed approx. 25 mm/sec.

Code for part numbers

Part no. 8919-06-X0-H

Stroke

2 = 200 mm

3 = 300 mm

4 = 400 mm

Technical data

Stroke [mm]	A [mm]	A + stroke [mm]	Weight [kg]
200	520	720	50
300	620	920	55
400	720	1,120	60

Dimensions

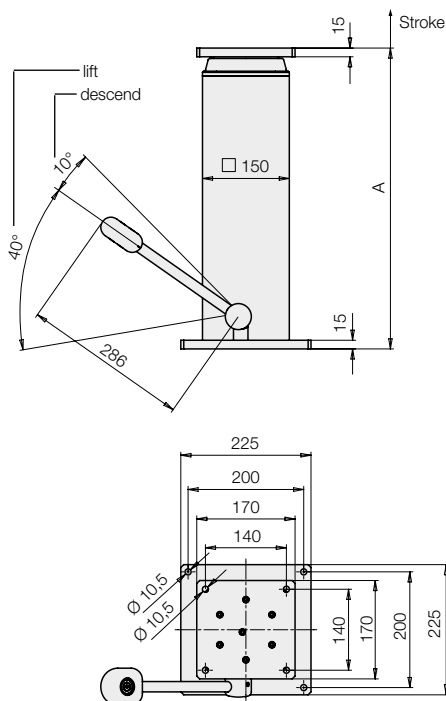

Maximum lifting force and maximum admissible torque load

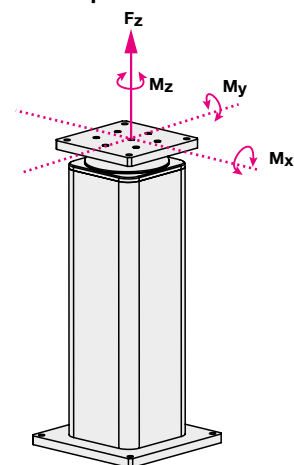

Accessories

Base plate for increased stability as per data sheet M 8.100

Important notes!

To descend the lifting module a minimum load of approx. 100 N is required.

The lifting module must only be pressure loaded. The centre of gravity should be within the traverse of the fixing screws.

If the centre of gravity is outside, the dowelled joint with the floor has to be dimensioned correspondingly. In such cases it is recommended to use a larger base plate.

In case of eccentric load of more than 250 mm, the column cannot descend automatically because of too high friction forces.

The lifting module is designed for applications within closed rooms.

Maximum lifting force Fz: 6,000 N

Maximum torque load:

Total Mx/y: 800 Nm

Mz: 400 Nm

In the case of eccentric loads, it is recommended to compensate these by counterweights. In off-position the indicated maximum torques may occur.

The forces and torques have to be considered by the operator. **During the lifting motion, only 50% of the maximum values are admitted.**

Electro-mechanical version operation with foot switch or hand panel



Description

The lifting motion is generated by an electric motor with a spindle lifting gear.

The electrically operated variant is particularly suitable for positioning and adjusting tasks of working tables as well as for material supply and transport.

They excel by a smooth running.

Operation

Lifting and lowering with hand panels or foot switches as per data sheet M 8.203 is triggered by touch control. After release of the push-button, the motion will be immediately stopped. The hand panel with memory function allows to store 5 positions, which can be approached via corresponding position push-buttons. (for detailed description see data sheet M 8.203)

Synchronization

Up to 4 lifting modules can be operated with synchronization control by a corresponding control module.

For example, complete lifting platforms can be designed.

For operation with synchronization control, only lifting modules with code letter G are suitable.

Control units with synchronization control for 2, 3, or 4 lifting modules are available.

Code for part numbers

Part no. **8919-06-X0-X**

Stroke

- 2** = 200 mm
- 3** = 300 mm
- 4** = 400 mm

Electronics

- E** = integrated stroke end disconnection (not suitable for synchronization control) with coiled connecting cable, 1.5 m
- G** = with incremental stroke measuring system (suitable for synchronization control) with smooth connecting cable, 2.5 m
- I** = with incremental stroke measuring system (suitable for memory function) with smooth connecting cable, 2.5 m
- B** = with incremental stroke measuring system (suitable for memory function and battery mode) with smooth connecting cable, 0.3 m

Dimensions

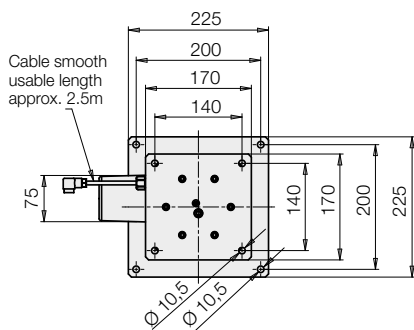
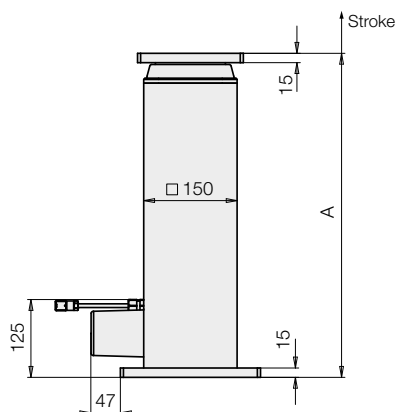

Accessories

Base plate for increased stability as per data sheet M 8.100

Technical data

Maximum lifting force F_z	6,000 N
Lifting speed (load-dependent)	
Electronics E I B	7...5 mm/s
Electronics G	6...4 mm/s
Electric connection	Plug
Duty cycle	15 % ED
Code class	IP 54
Control voltage	24 VDC
(Power input)	200 W)
Current consumption	max. 8 A

Delivery

The lifting modules are delivered ready for connection. The connecting cable from the lifting module to the control module is included in the delivery. Operating elements as well as control modules and mains cables can be ordered separately as an accessory.

Electrical accessories required for a functional system:

- Control module as per data sheet M 8.200 or
- Control module with battery holder as per data sheet M 8.201
- Hand panels, foot switch and mains cable as per data sheet M 8.203