

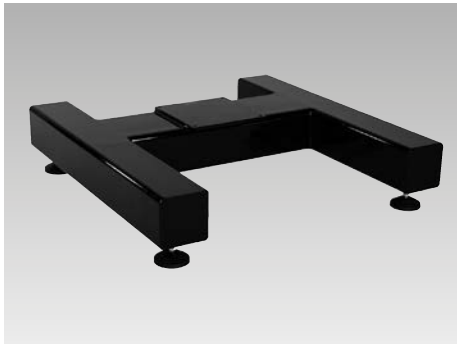

Floor Module FMS

Max. load 6,000 N, with one modulog interface



Application

Floor modules for use as base frame for height-adjustable working places. Working stations or height-adjustable working tables can be easily realised with floor modules combined with lifting units. Floor modules are a stable base that can be adapted to uneven floors for further setups with high stability.

Principal use

- Production plants
- Test area for quality assurance
- Height-adjustable standing working places
- Height-adjustable working tables

Installation

The floor module with adjustable feet has to be adjusted so that all sides are supported on the floor. Afterwards the adjustable feet have to be locked by lock nuts.

Important notes

When installing the floor module pay attention to a stable floor. Protruding loads have to be avoided as this may cause instability.

Advantages:

- Stable steel construction with high load capacity
- Height-adjustable feet
- Solid and upright position even on uneven floors
- Good accessibility
- Suitable for workshop setups
- Suitable as base frame for working tables
- modulog interface

Description

The floor module FMS consists of a welded, stable steel frame with four height-adjustable feet. The adjustable feet have a steel thread and are equipped with a stable spherical cap. In the centre of the steel frame a mounting plate with a modulog interface 200 x 200 is fixed. This plate is used to fix modulog modules. Alternatively workshop setups can be mounted onto the steel frame.

Material

Frame: steel, black-lacquered

Mounting

For mounting of modulog modules or other components the floor module has in the centre of the steel frame an interface 200 x 200. As accessory an adaptor plate is available to mount modulog modules with interface 140 x 140. To combine working tables appropriate table plates with handles are available as accessory.

modulog Flurmodul FMS

Part no. 8901-06-01-0

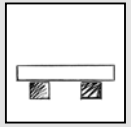

Technical data

Max. load: 6,000 N

Combinable with the modules

- Lifting modules as per data sheet M 4.XXX



modulog interface

- 200 x 200 - M10

Accessories

- Table plates as per data sheet M 8.130

Application example



Floor module FMS 600 with mounted electrical lifting module Shop-Floor.

Technical data Dimensions

Maximum admissible load F_z

Due to stability reasons, only symmetrical load is admitted for the floor module.

Maximum admissible load $F_z = 6,000\text{ N}$

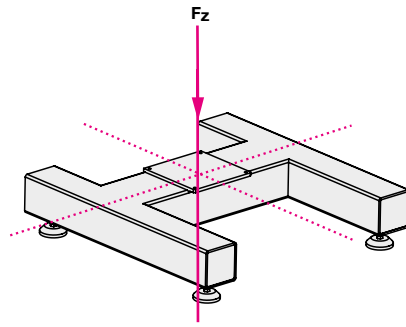

Part no. 8901-06-01-O

Accessories

• **Adaptor plate 140 - 200**
to mount modulog modules with interface
140 x 140

• **Part no. 6311-417**

See data sheet M 8.110

• **Table plates made of wood or steel**

See data sheet M 8.130

Spare part

• **Adjustable foot**

Part no. 6351-568

Dimensions

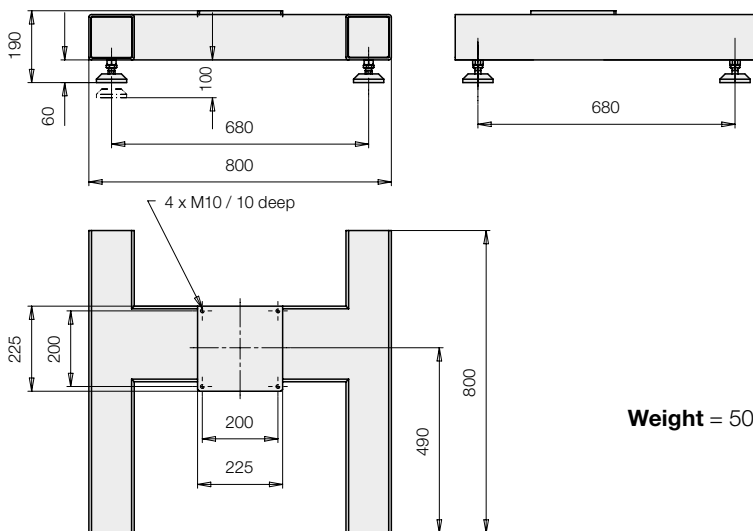

Weight = 50 kg