

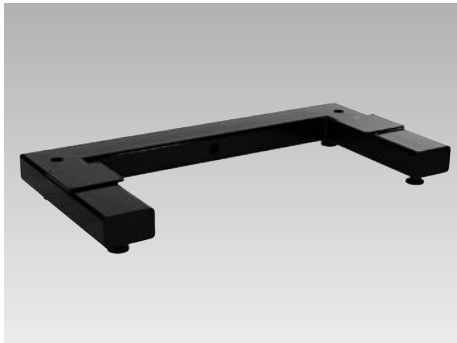

Floor Modules

for 1 or 2 *modulog* lifting modules



Advantages

- High stability of the lifting modules
- Compensation of uneven floors
- High load capacity
- Stable steel construction
- *modulog* interfaces
- With bore holes for cabling

Application

Floor modules are used as a base frame for *modulog* lifting modules. They are a stable base that can be adapted to uneven floors for further setups with high stability.

Height-adjustable working tables can be easily composed by floor modules and *modulog* lifting modules.

Customised versions

Floor modules are manufactured according to the customer requirements.

For example, depending on the number of lifting modules, the required loads and the spatial conditions.

Please contact us!

Description

Floor modules consist of a welded, stable steel frame with four height-adjustable articulated feet to compensate uneven floors.

On the steel frame there are one or two mounting plates for *modulog* lifting modules. Each mounting plate is provided with a *modulog* interface 200 x 200 mm – M10, the hole pattern to fix the *modulog* lifting modules.

Material

steel, black-lacquered

modulog interface 200 x 200 mm – M10

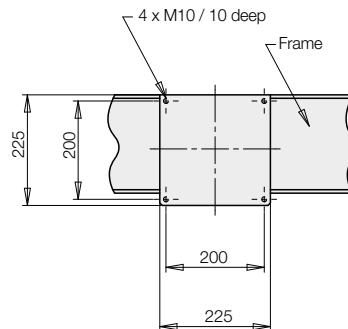

modulog Floor modules

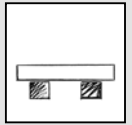

Part no. on request

Combinable with the modules

- Lifting modules as per data sheet M 4.XXX



modulog interface

- 200 x 200 – M10
Number: 1 or 2

Accessories

- Table plates as per data sheet M 8.131

Application example

Floor module for 2 lifting modules



Height-adjustable working tables composed by floor module, two electrically-operated lifting modules Shop-Floor with control module and one table plate.

Application example

Floor module for 1 lifting module



Floor module with electrical lifting module Shop-Floor.